

start white side up

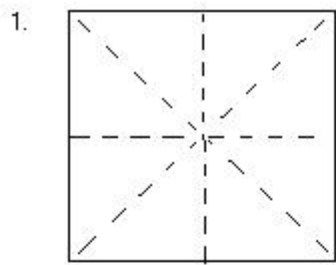

1. Precrcrease the paper in half in all 4 directions

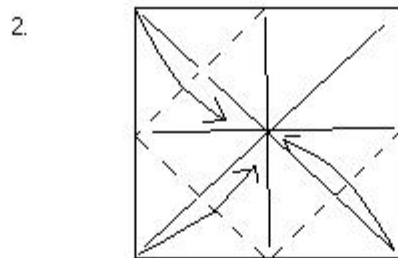

2. Fold three of the corners into the middle

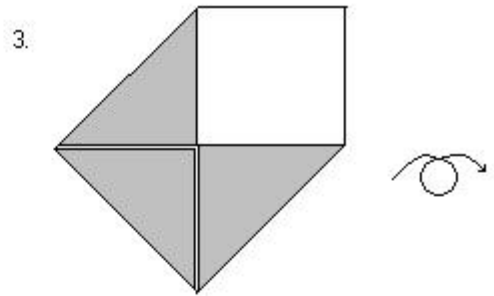

3. Turn over and rotate

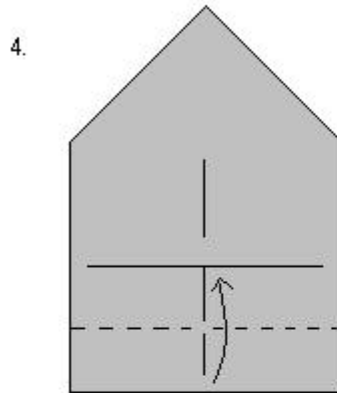

4. Fold to the center

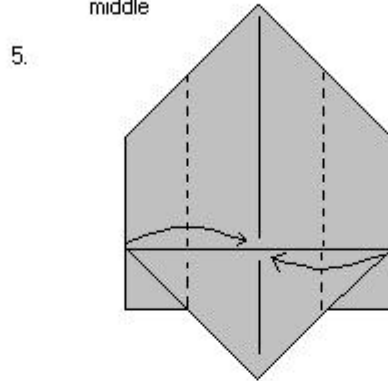

5. Fold to the center

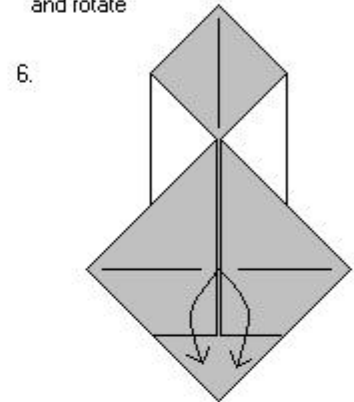

6. Pull out the 2 points

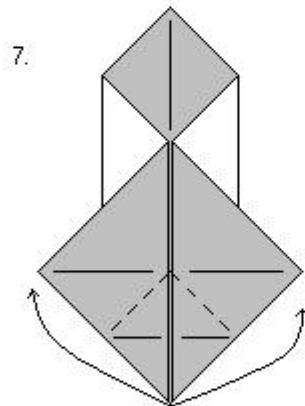

7. 2 valley folds

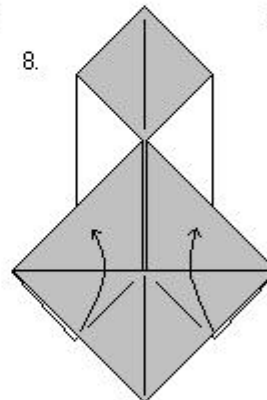

8. Reverse fold the 2 triangles out from inside

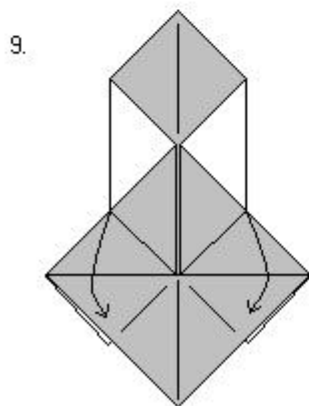

9. Fold the flaps down

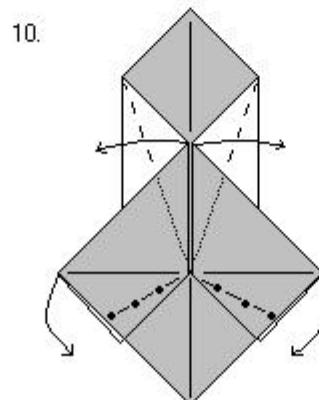

10. Squash folds

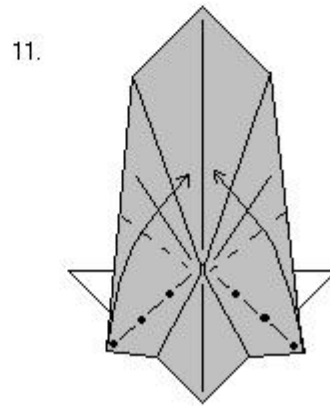

11. Swivel he points up

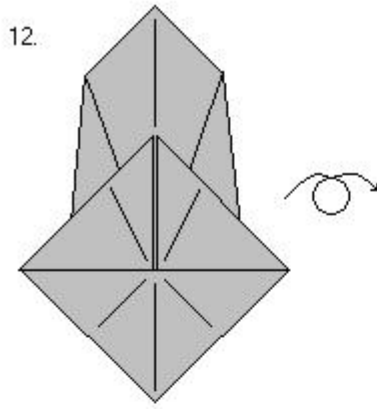

Turn over

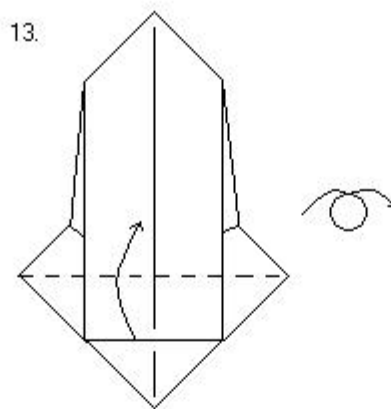

Valley fold the thick flap up
Turn over

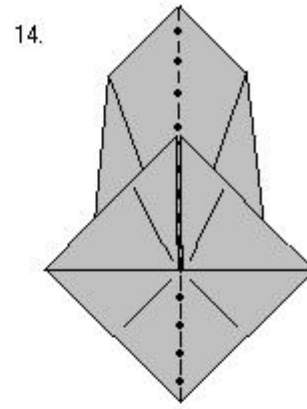

Fold in half and rotate

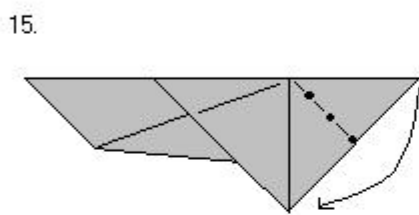

Reverse fold

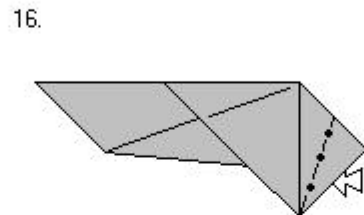

Reverse fold
Repeat behind

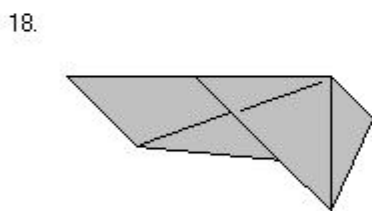
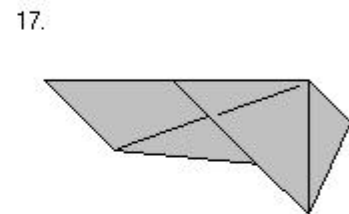

Unfold the reverse folds

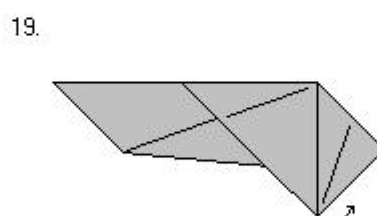

Pull the center point
out a little bit

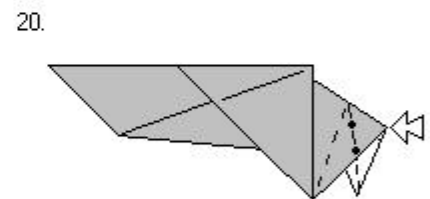

Squash fold
Repeat behind

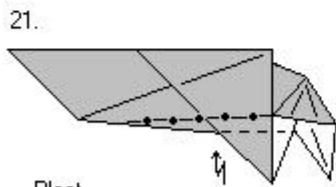

Pleat
Repeat behind

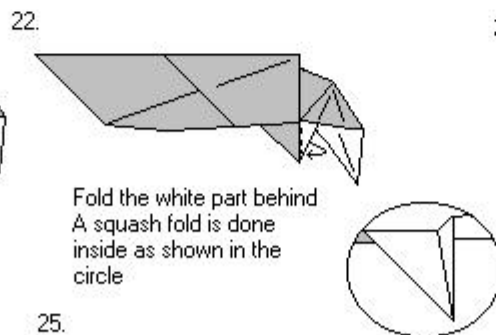

Fold the white part behind
A squash fold is done
inside as shown in the
circle

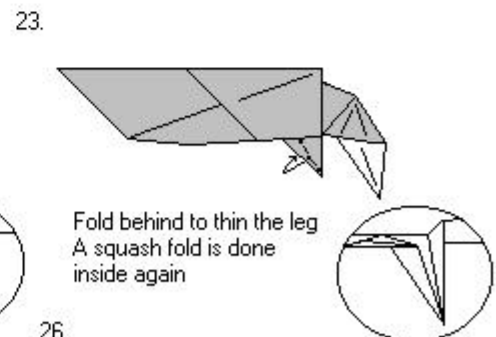

Fold behind to thin the leg
A squash fold is done
inside again

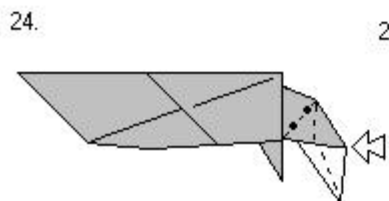

Swivel to thin the neck

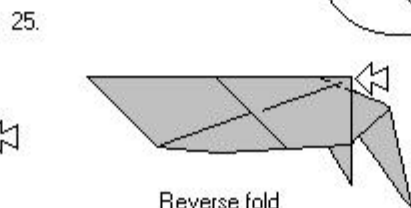

Reverse fold

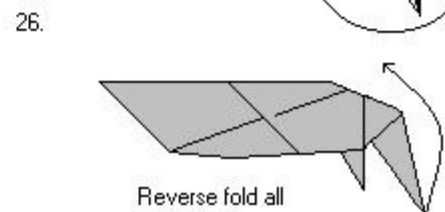

Reverse fold all
the way up

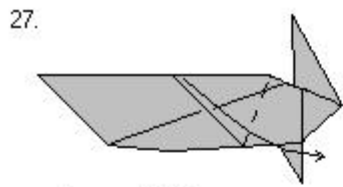

Repeat behind

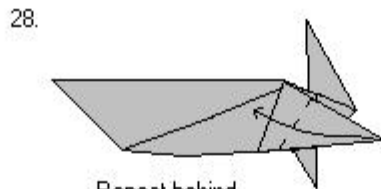

Repeat behind

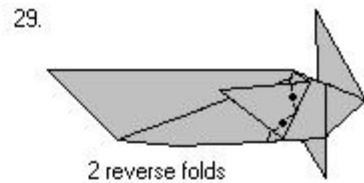

2 reverse folds
Repeat behind

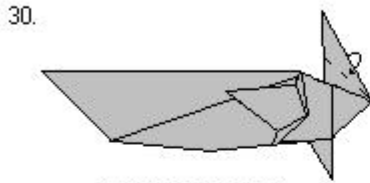

Outside reverse fold

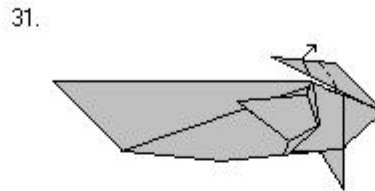

Outside reverse fold

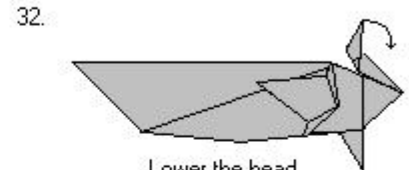

Lower the head
with a crimp

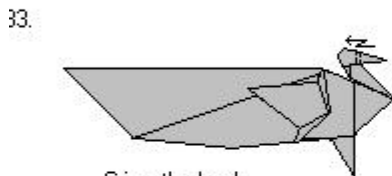

Crimp the beak

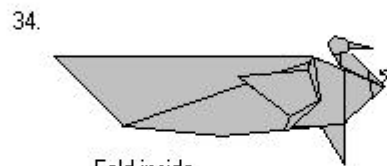

Fold inside
Repeat behind

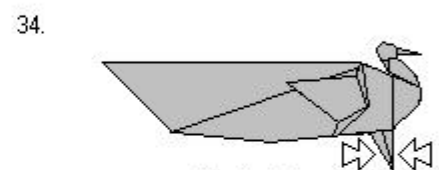

Pinch the leg
Repeat behind

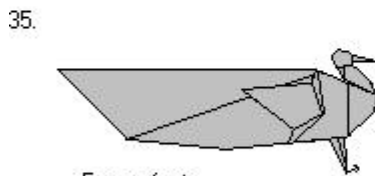

Form a foot
Repeat behind

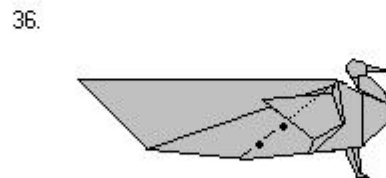

Form a foot

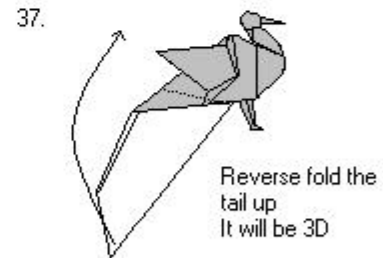

Reverse fold the
tail up
It will be 3D

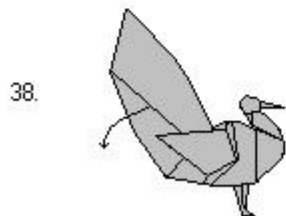

Pull out the paper

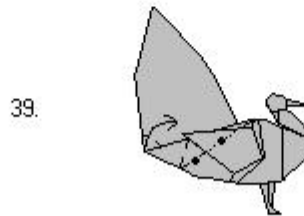

Fold the paper inside

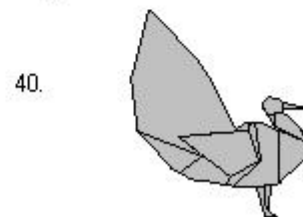

Peacock