

L'OISEAU BLANC

Les oiseaux blancs, c'est rien que des histoires pour faire rêver les enfants d'Amerzone...

L'Amerzone / Benoit Sokal - Editions Casterman

Papier conseillé : carré de papier blanc des deux côtés, fin (papier de riz), de 20 cm de côté environ.

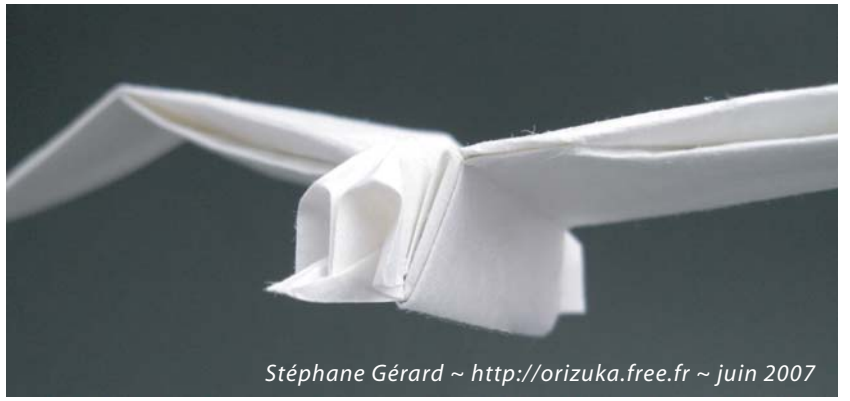

Stéphane Gérard ~ <http://orizuka.free.fr> ~ juin 2007

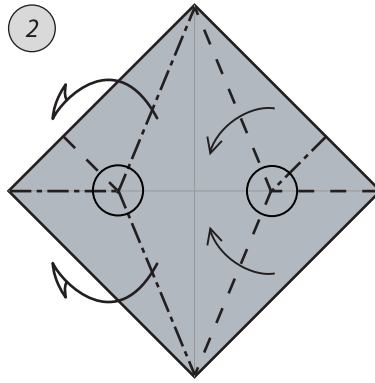
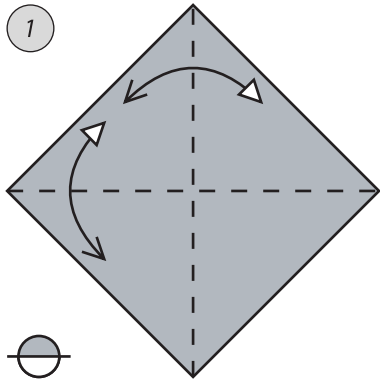

Oreilles de lapin. Ne pas marquer au-delà des centres des triangles.

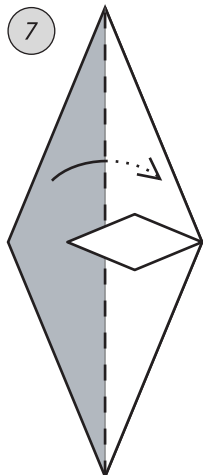
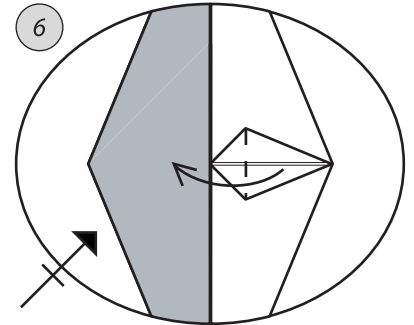
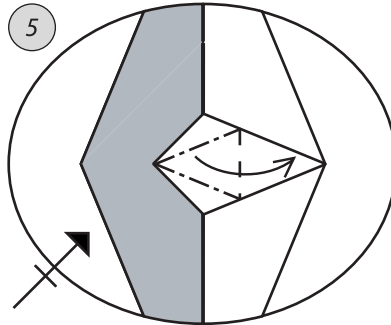
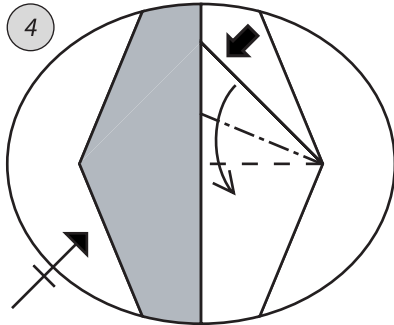
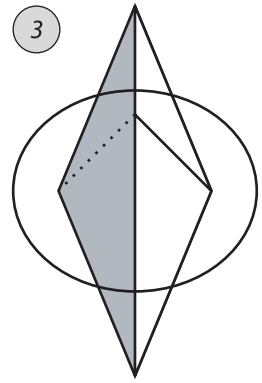

Insérer le volet de gauche dans celui de droite.

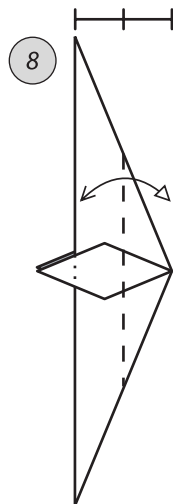

Enfoncement fermé.

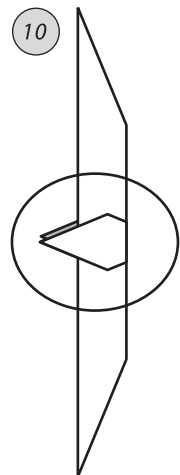
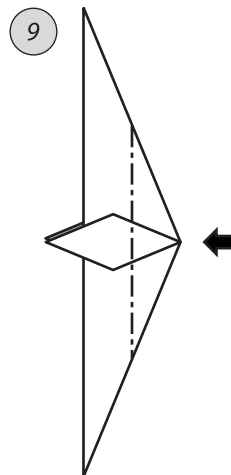

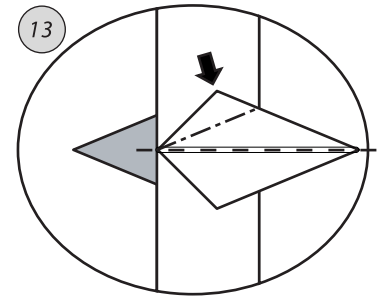
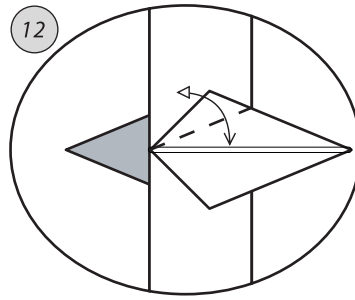
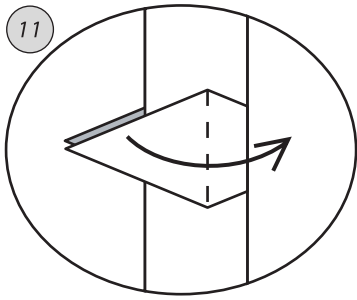

Enfoncement étiré.

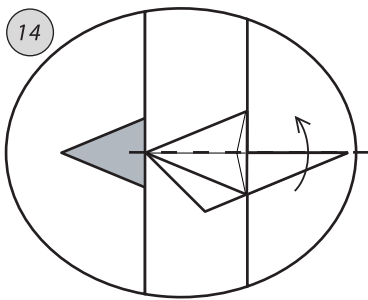

Relever le volet et répéter 12-14 sur l'autre moitié.

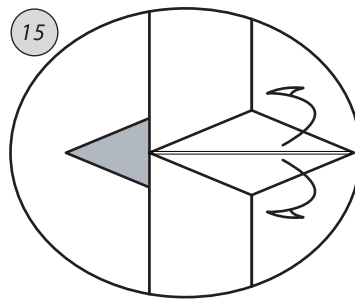

Changement de couleur.

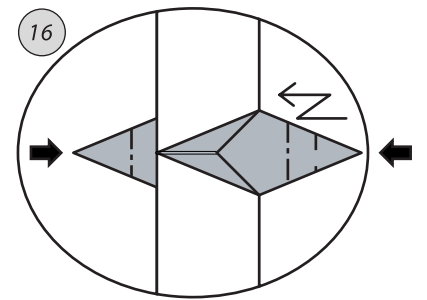

Enfoncements ouverts.

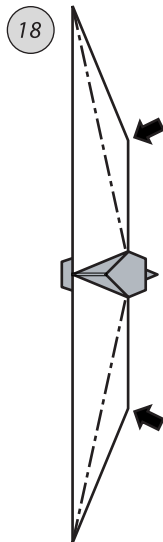
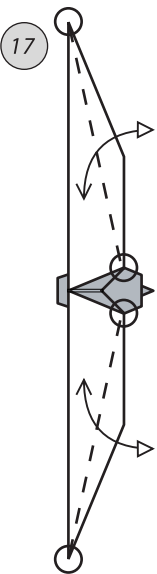

Enfoncements fermés.

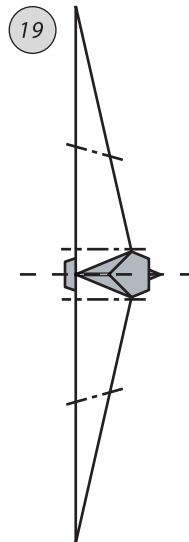

Mettre le corps en forme.

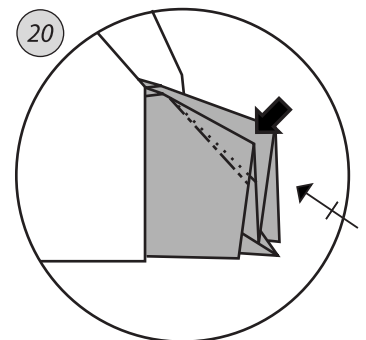

Modeler les yeux en enfonçant légèrement les "arcades".

