

マンモス

MAMMOTH

作／図 宮島 登

Design & Diagrams By Noboru Miyajima

創作 1997年9月

作図 2000年11月

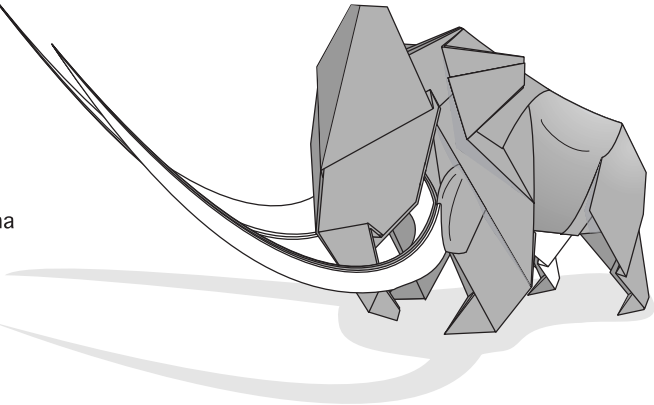

①

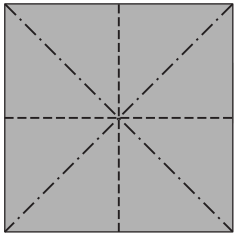

折り筋をつける

②

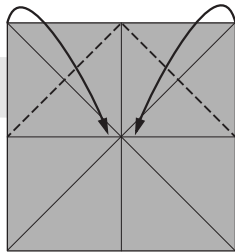

③

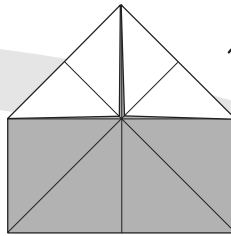

④

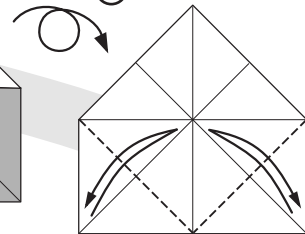

⑤

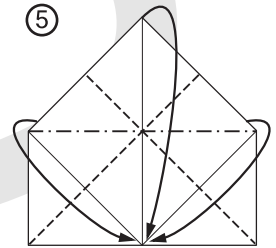

風船の基本形の要領でまとめる

⑦

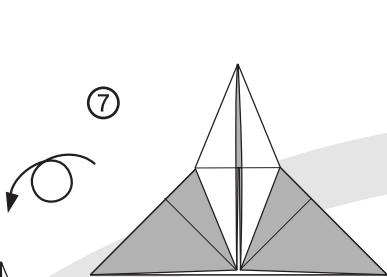

⑥

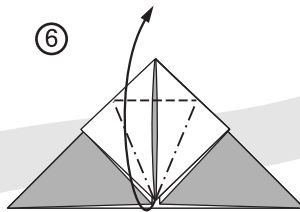

⑧

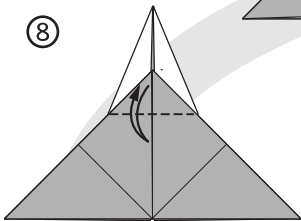

⑨

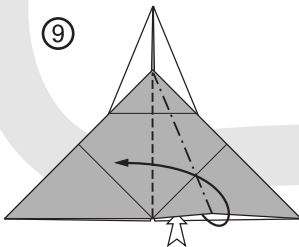

⑩

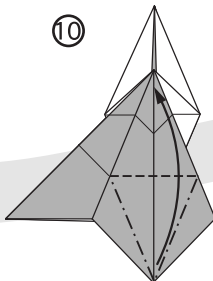

⑪

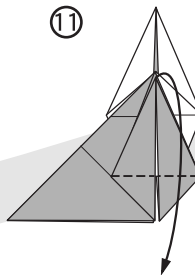

⑫

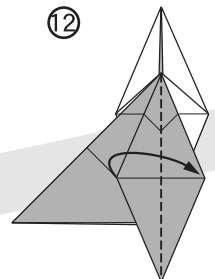

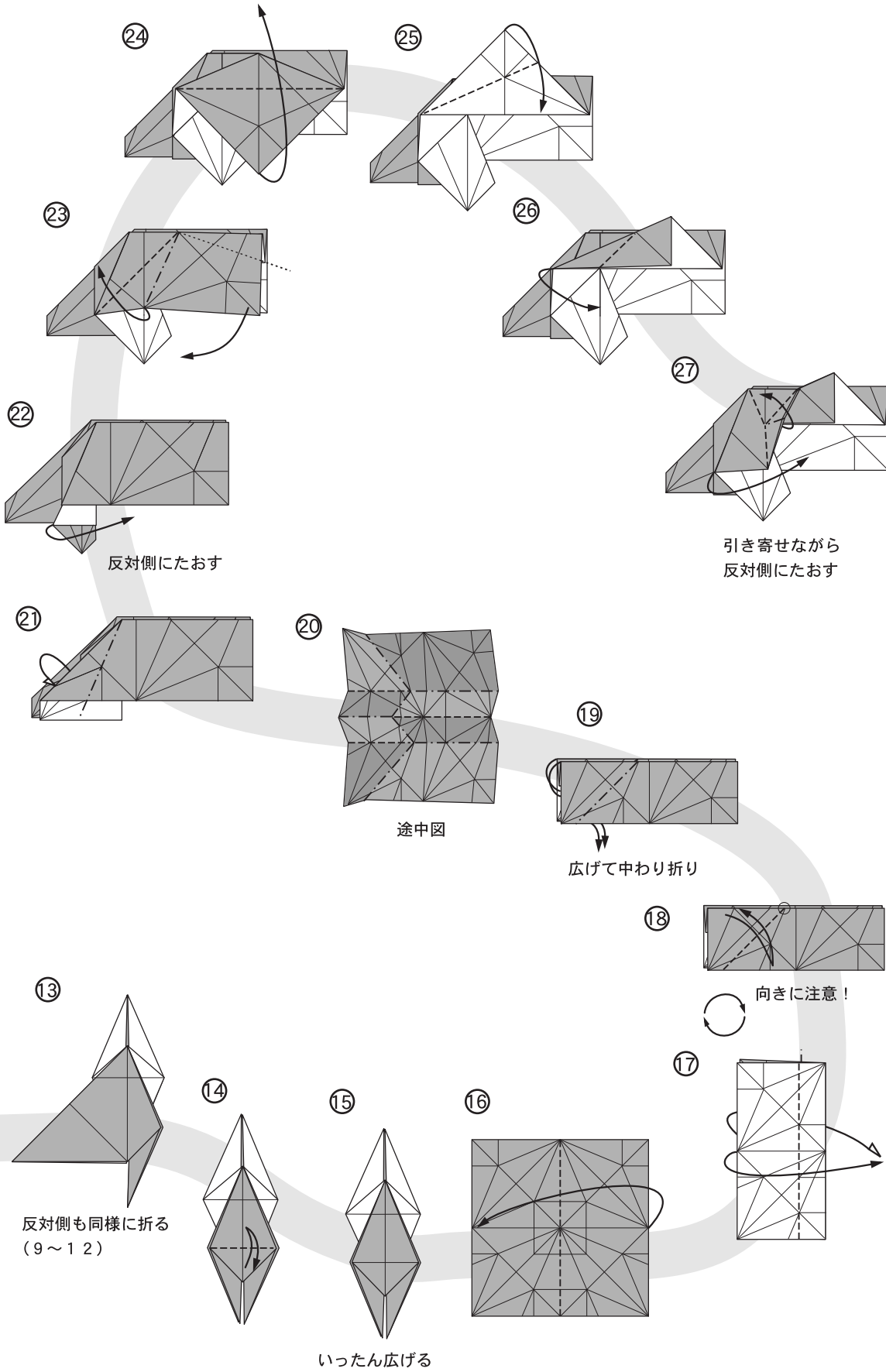

反対側も同様に折る
(9~12)

いったん広げる

途中図

広げて中わり折り

引き寄せながら
反対側にたおす

反対側にたおす

向きに注意!

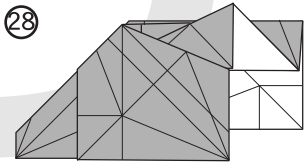
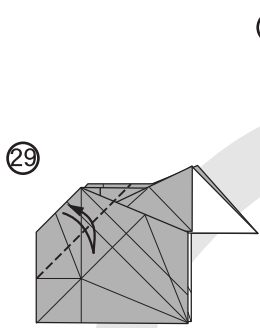

反対側も同様に折る
(2 1 ~ 2 7)

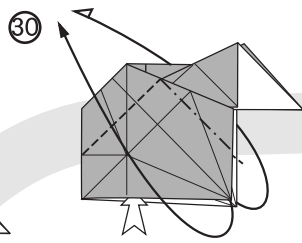

かぶせるように折る

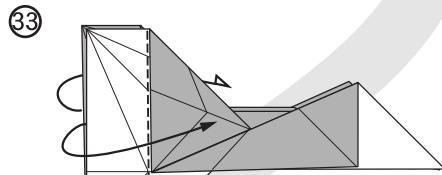
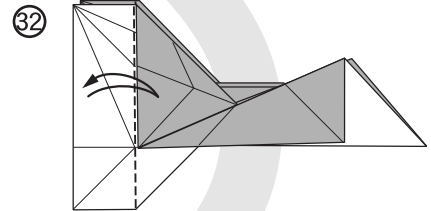
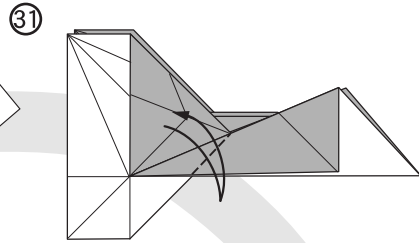

かぶせるように折る

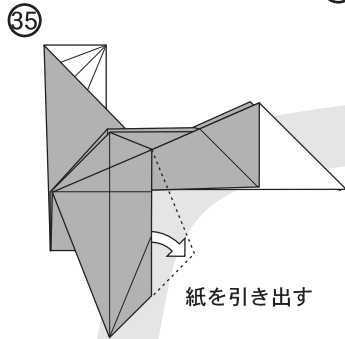
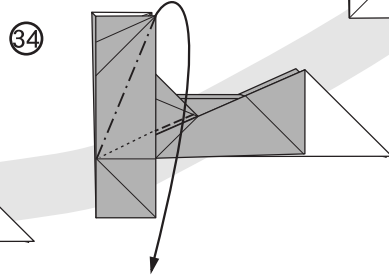

紙を引き出す

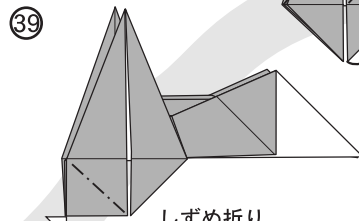
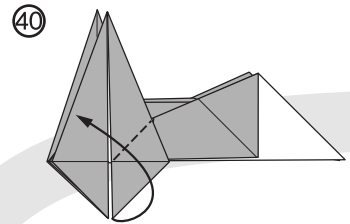
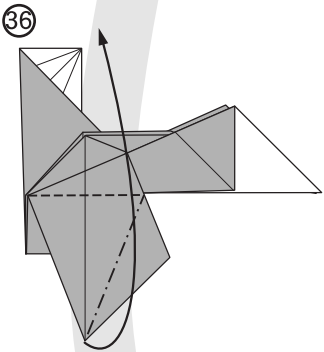

しずめ折り
(Open Sink)

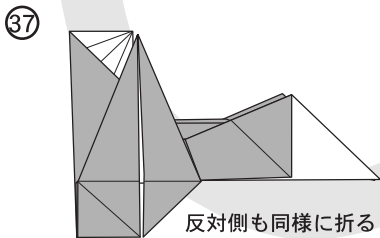
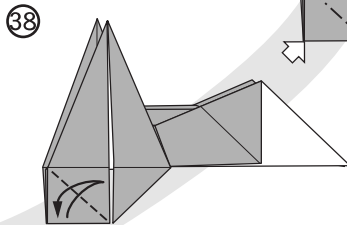

反対側も同様に折る
(3 4 ~ 3 6)

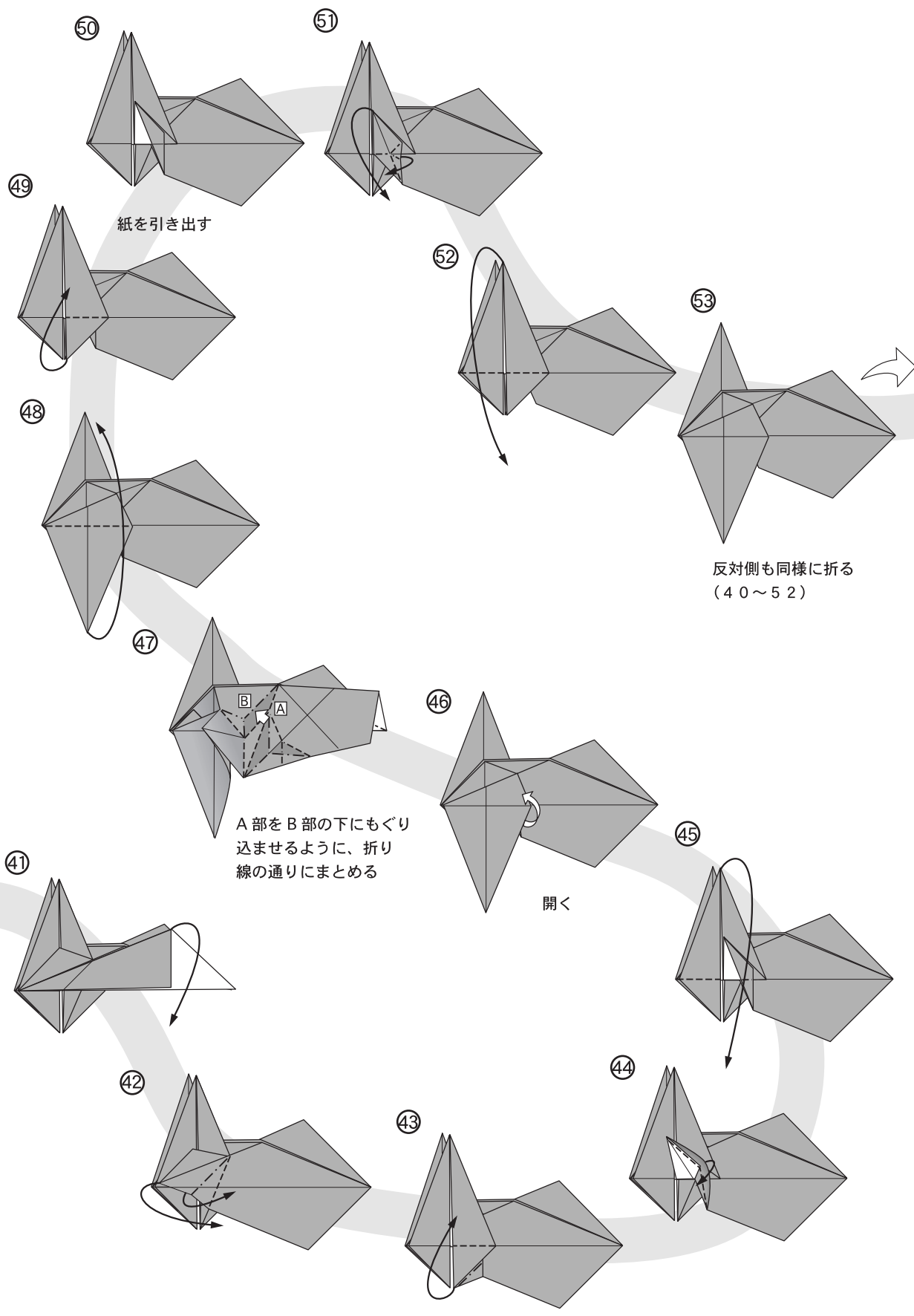

50

51

49

紙を引き出す

52

53

48

反対側も同様に折る
(40~52)

47

A部をB部の下にもぐり
込ませるように、折り
線の通りにまとめる

46

開く

45

41

42

44

43

55

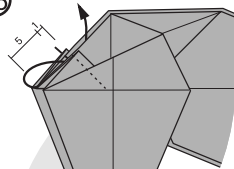

約 6 / 1 のところで中わり折り

56

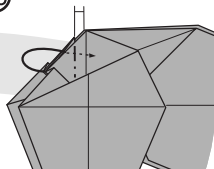

中わり折り
反対側も同じ

57

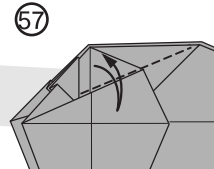

58

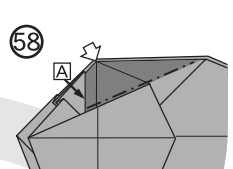

しずめ折り (Open Sink)
ただし、A部の重なりは
そのままにすること

54

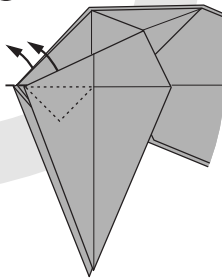

中わり折り

60

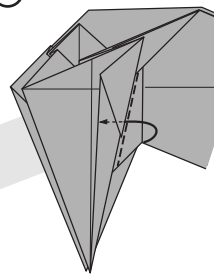

61

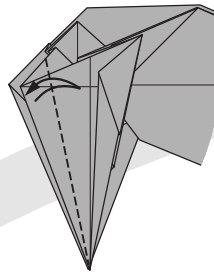

折り筋をつける
(中心線に合わせるのではなく
右側と同じ幅で折ること)

59

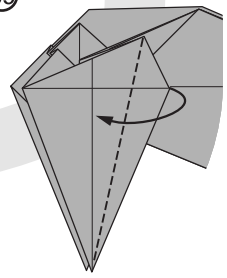

62

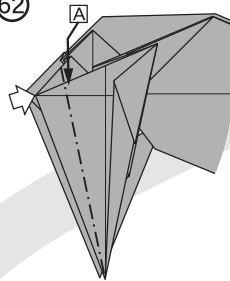

しずめ折り (Open Sink)
ただし、A部の重なりは
そのままにすること
また、下側に隠れている
角は先まで細く折らない
(65図参照)

63

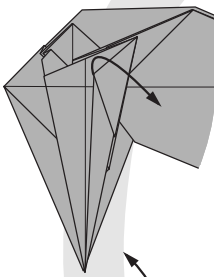

67

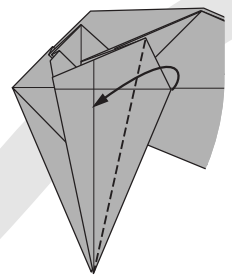

64

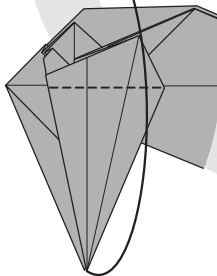

65

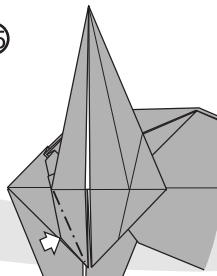

しずめ折り (Closed Sink)

66

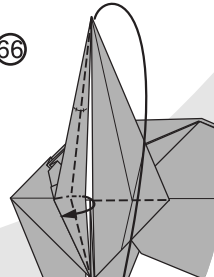

上部の角をについて、縁に
合わせて折るようにして、
全体を折り下げる

76

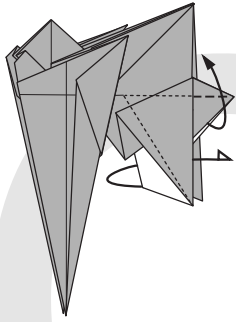

77

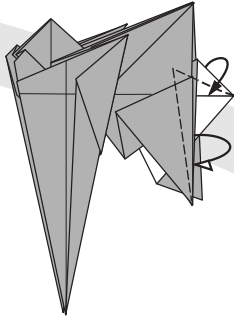

78

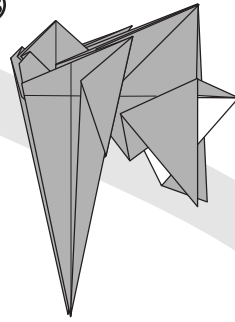

79

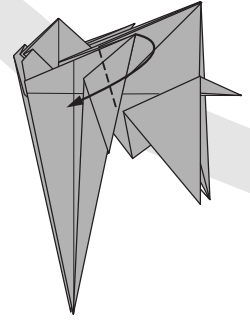

反対側も同様に折る
(76~77)

75

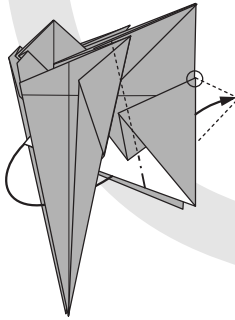

74

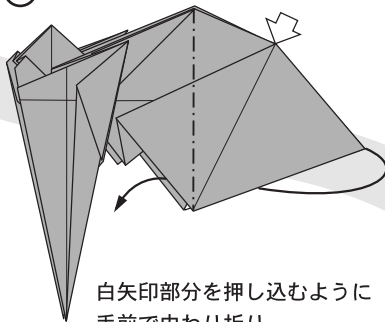

中わり折り

白矢印部分を押し込むように
手前で中わり折り

73

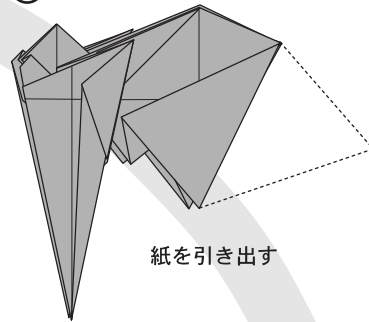

紙を引き出す

68

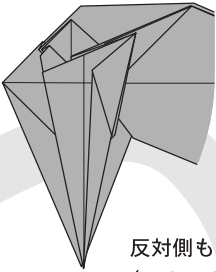

反対側も同様に折る
(56~67)

72

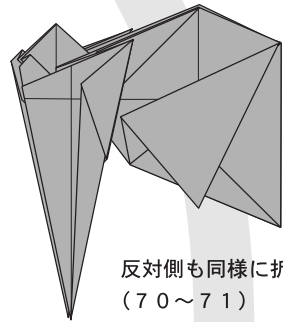

反対側も同様に折る
(70~71)

69

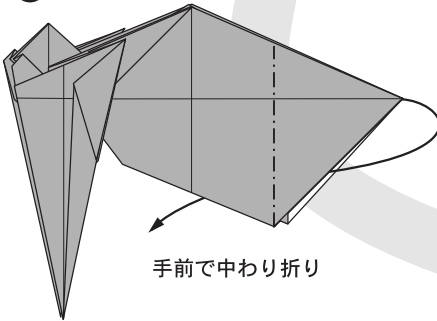

手前で中わり折り

70

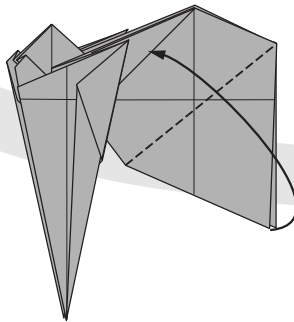

71

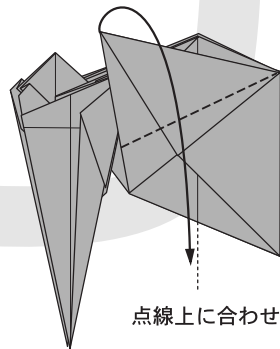

点線に合わせる

80

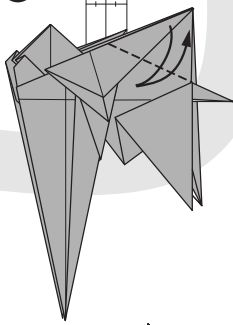

74図の状態
まで戻す

81

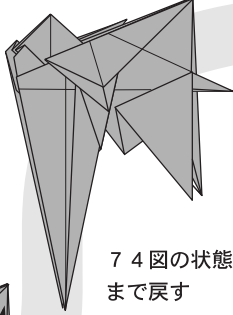

82

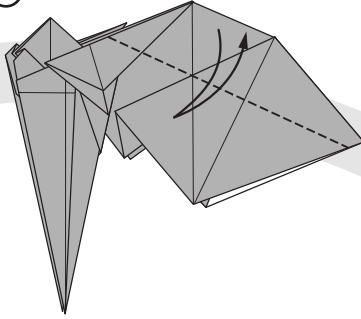

83

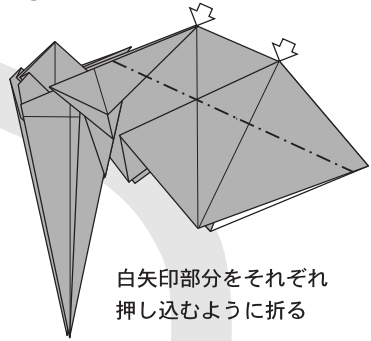

白矢印部分をそれぞれ
押し込むように折る

84

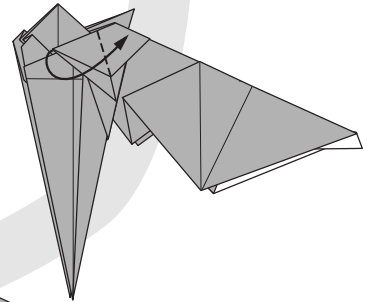

85

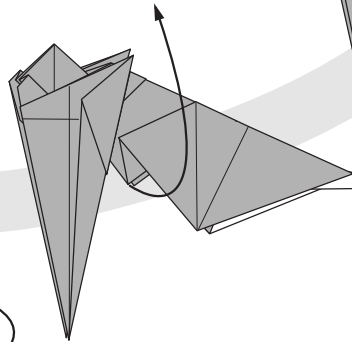

86

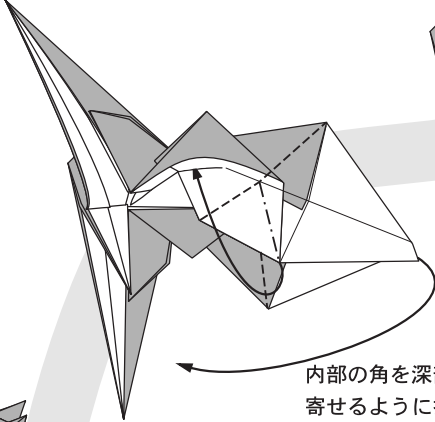

内部の角を深部に引き
寄せるように折る

87

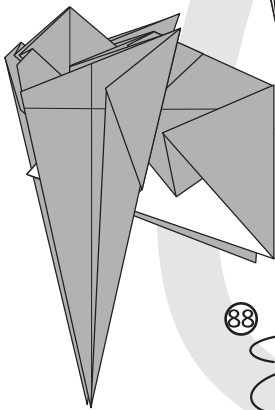

75~78の行程をくり返す
(ただし、上部がロックされ
ているため折りにくい)

89

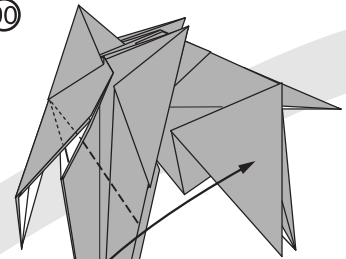

88

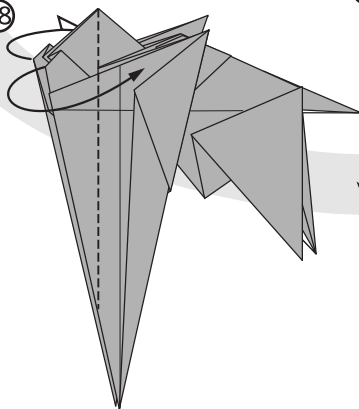

89

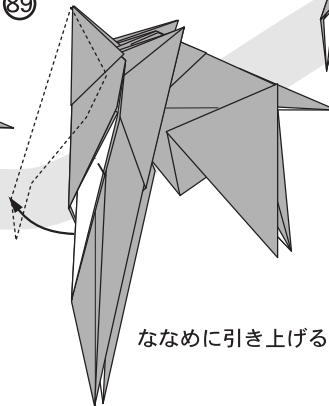

ななめに引き上げる

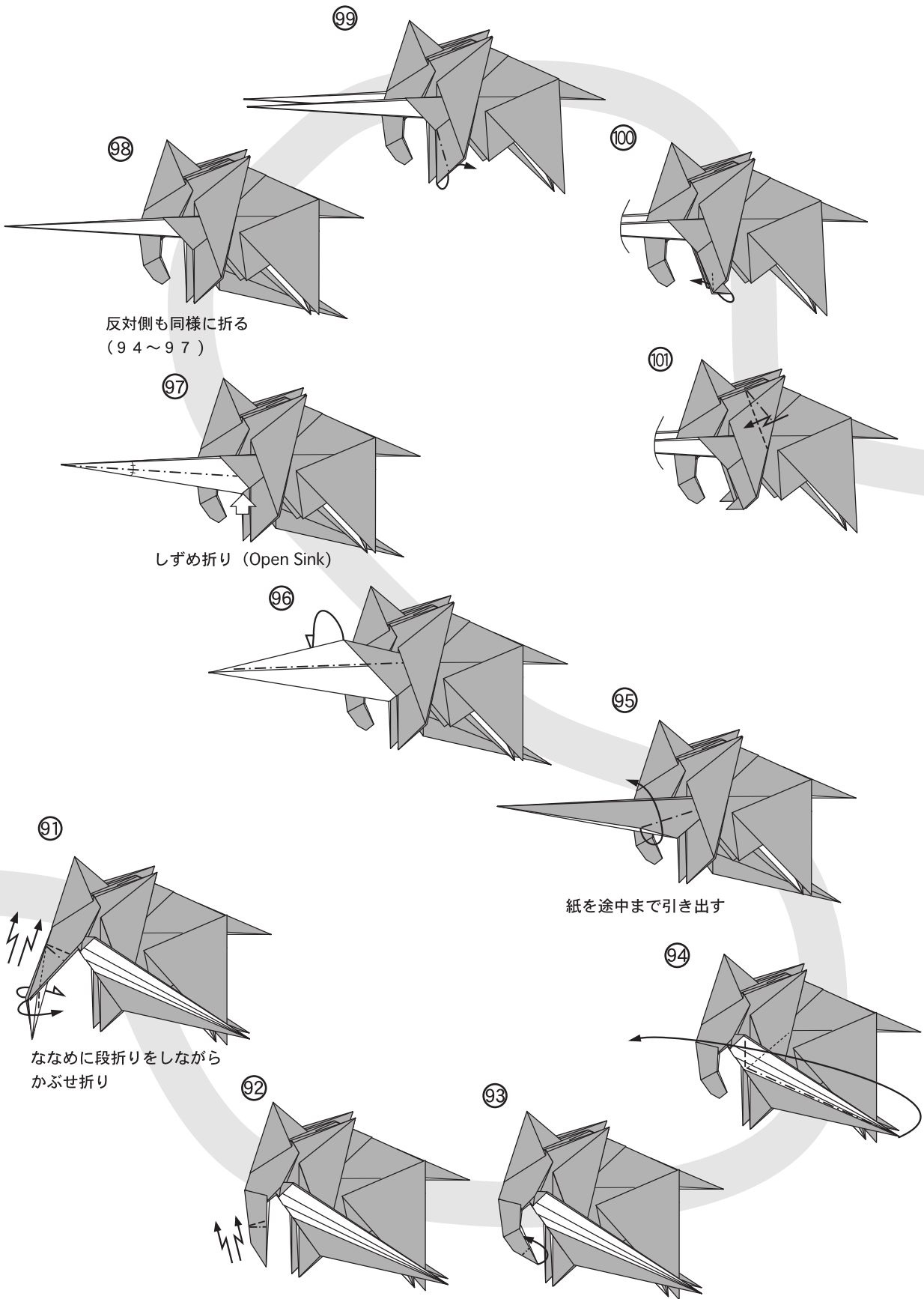

反対側も同様に折る
(94~97)

しずめ折り (Open Sink)

紙を途中まで引き出す

ななめに段折りをしながら
かぶせ折り

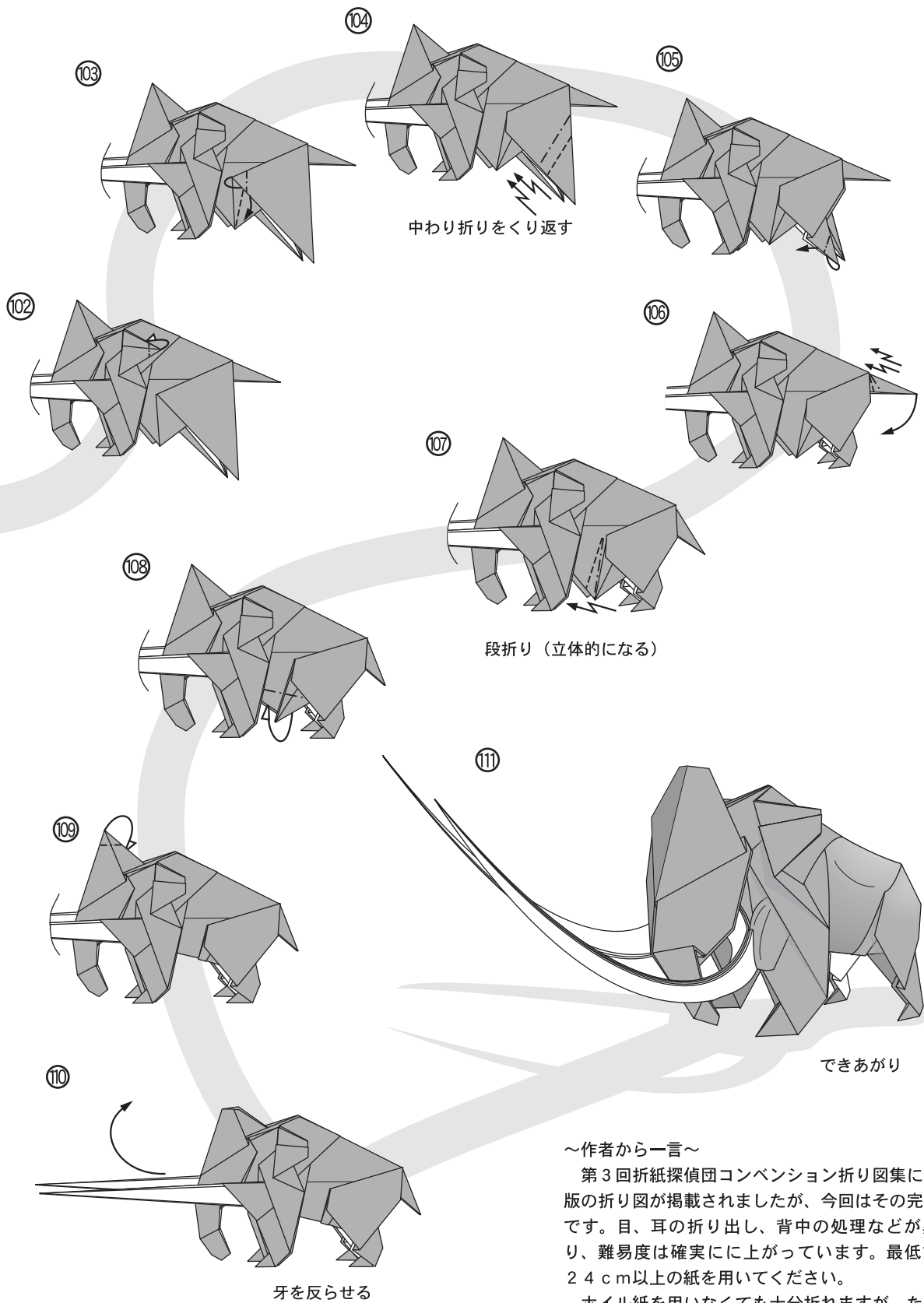

～作者から一言～

第3回折紙探偵団コンベンション折り図集に簡易版の折り図が掲載されましたが、今回はその完全版です。目、耳の折り出し、背中中の処理などが異なり、難易度は確実に上がっています。最低でも24cm以上の紙を用いてください。

ホイル紙を用いなくても十分折れますが、ただ牙の形が決まらないと思います。私は、牙の部分全体をボンド付けて、ドライヤーで乾かして形を固定するという荒療治をすることが多いです。