

# MAPACHE de EDWIN CORRIE

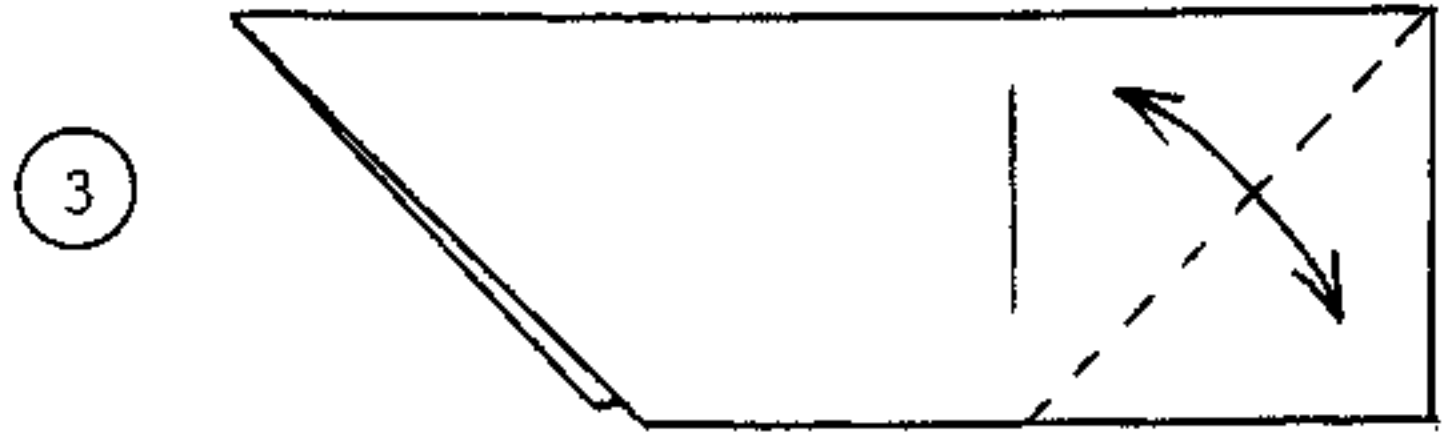

Lado coloreado encima

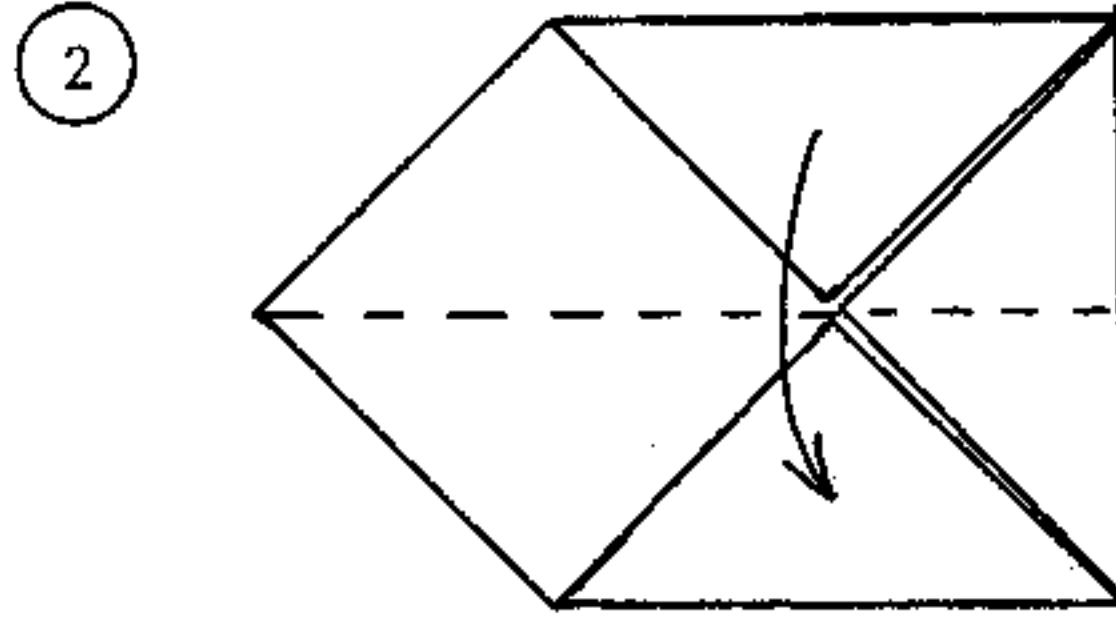
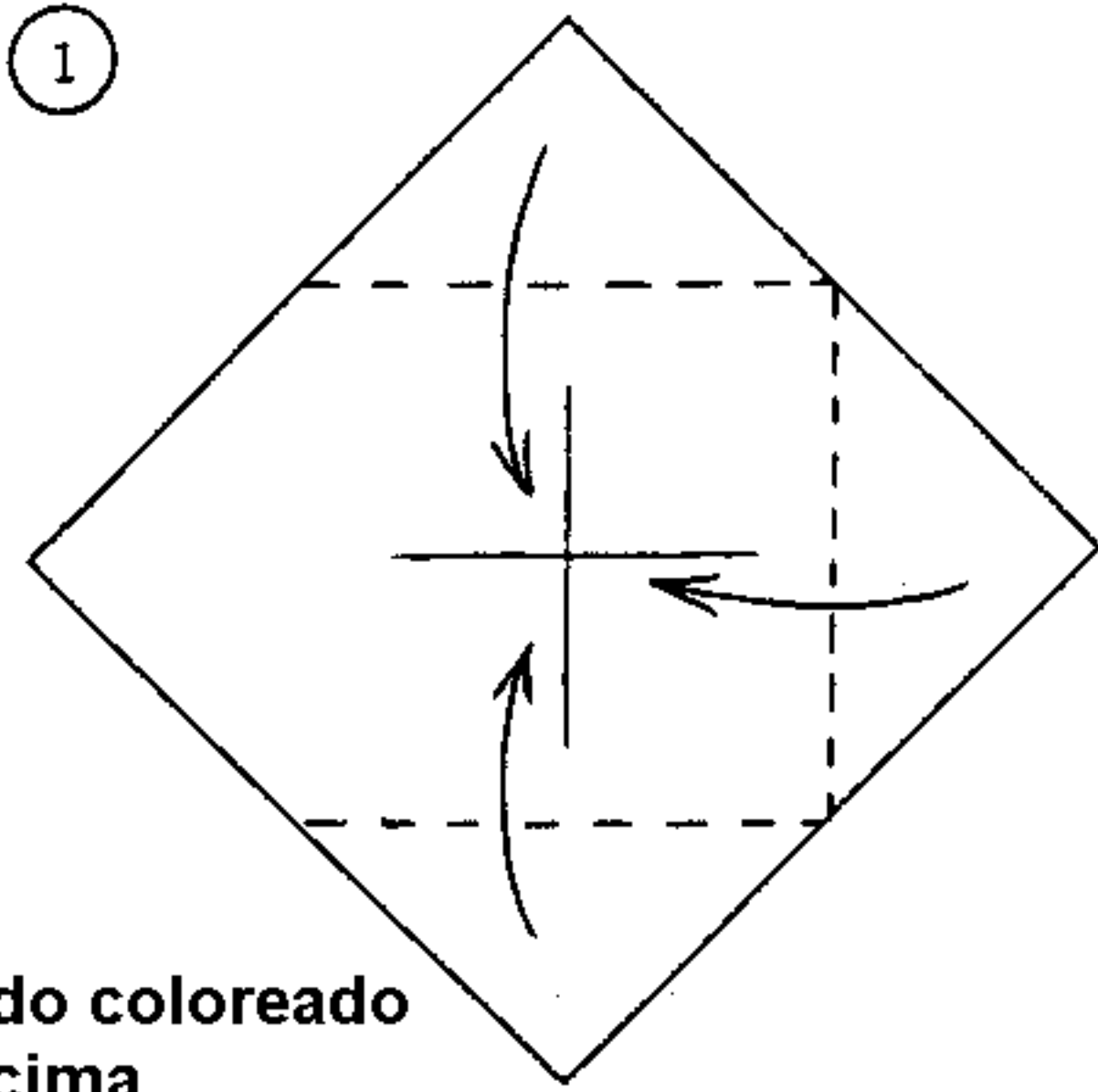
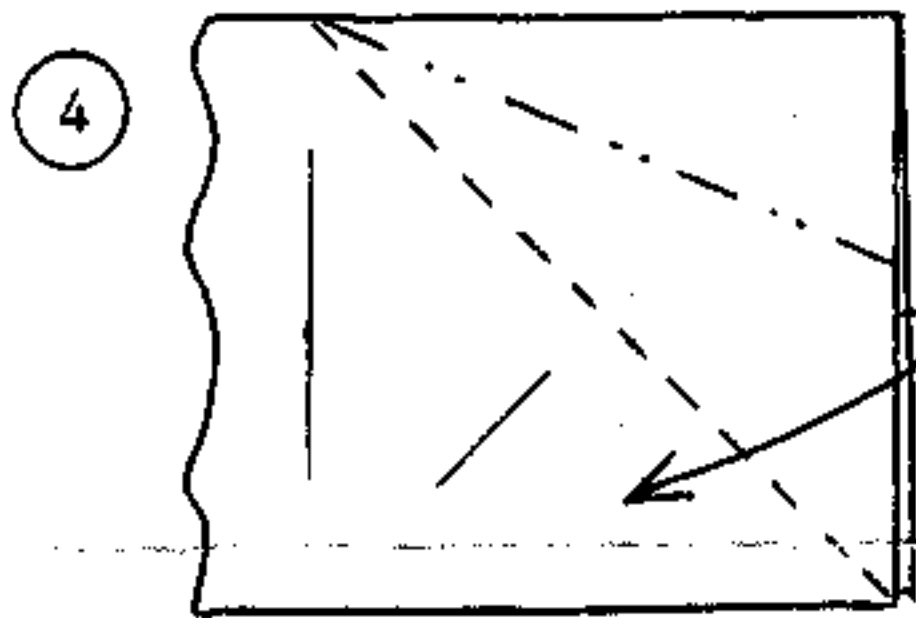

Aplastar

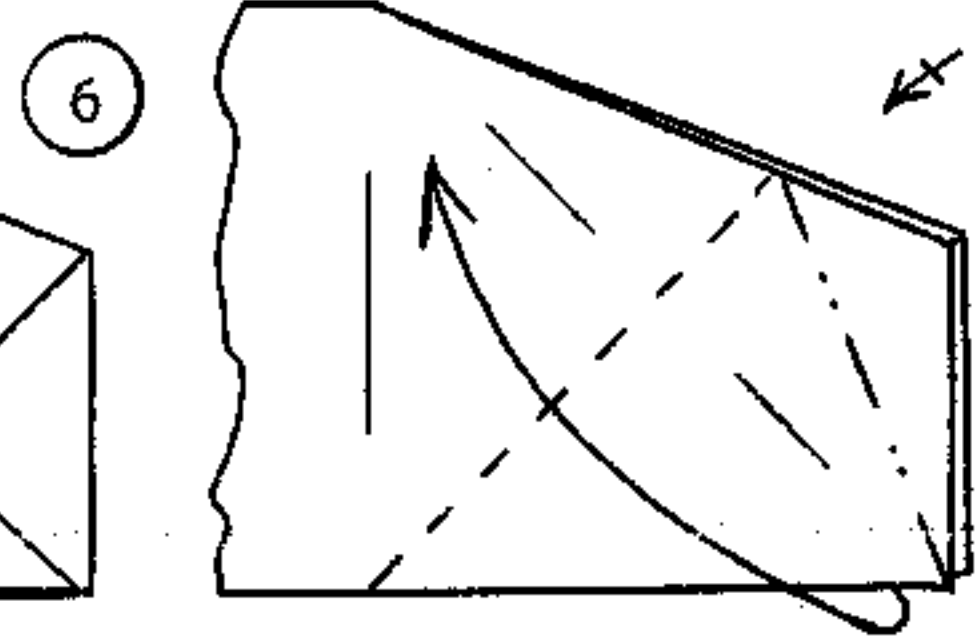
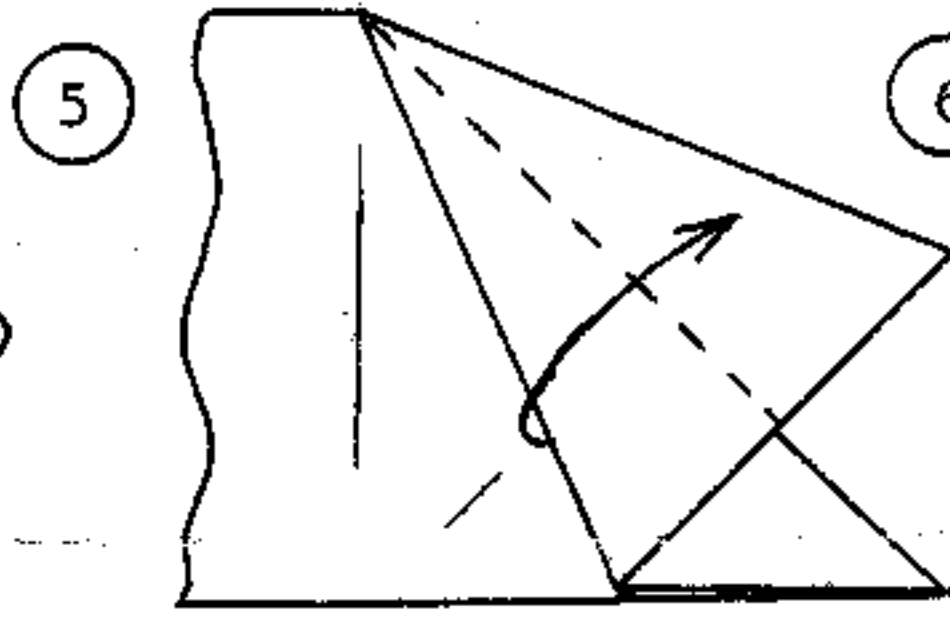

Pliegue en petalo

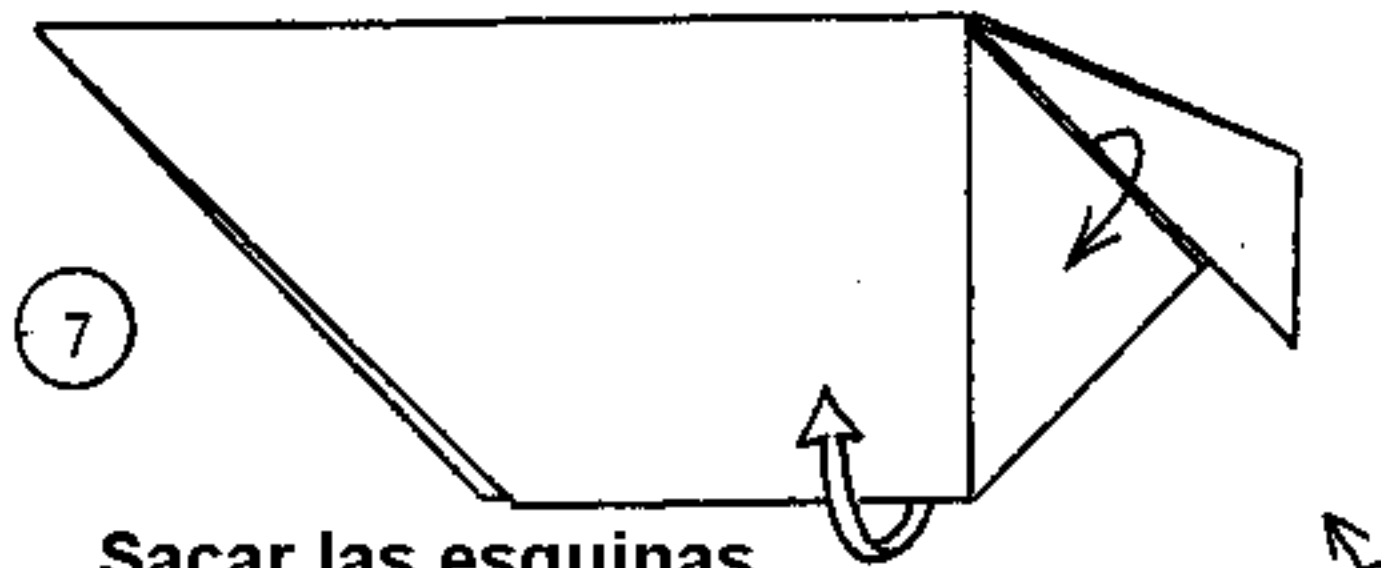

Sacar las esquinas escondidas (delante y detrás)

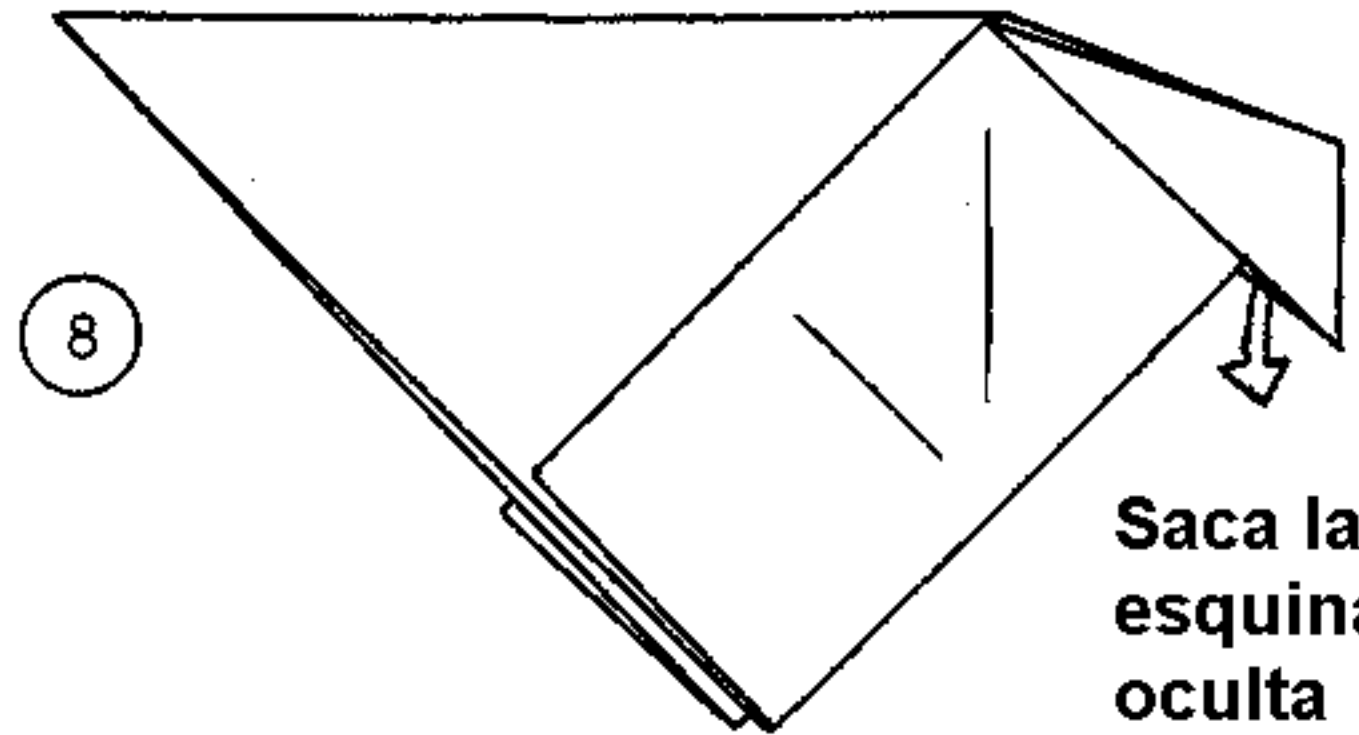

Saca la esquina oculta

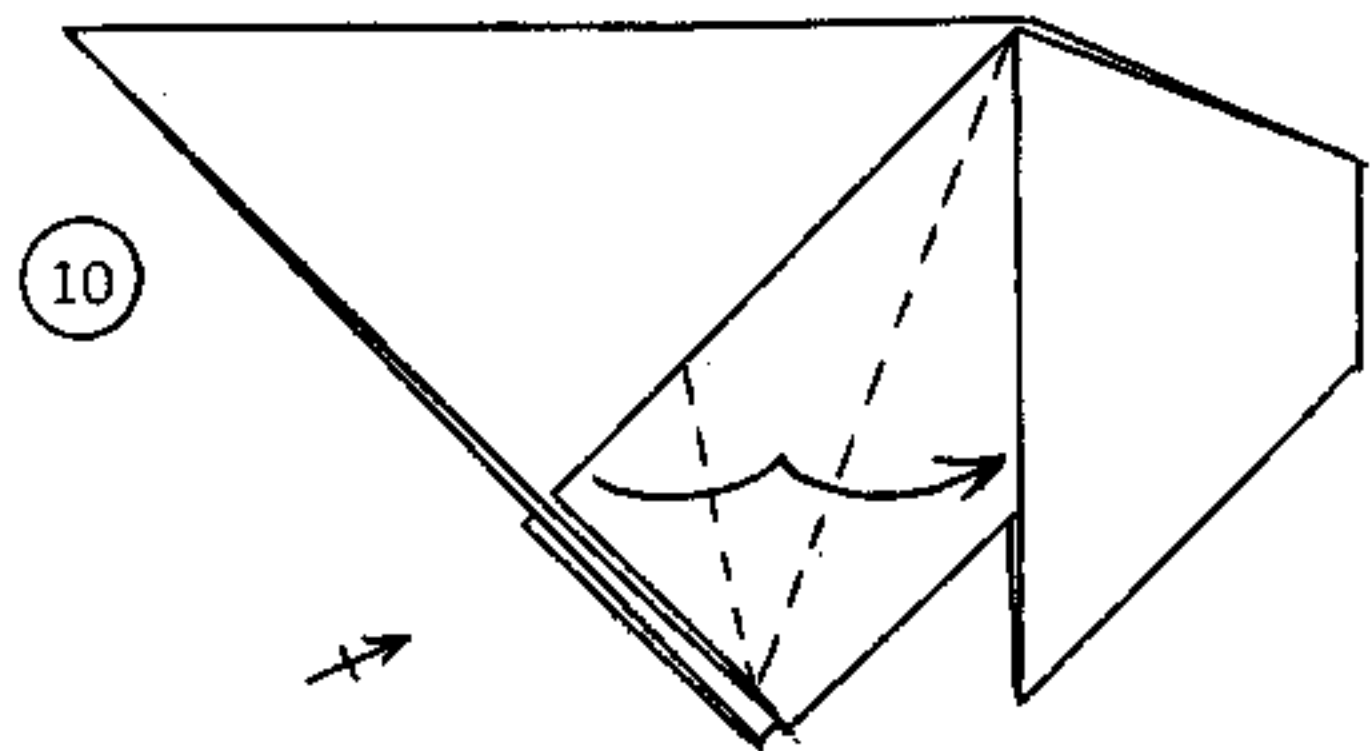
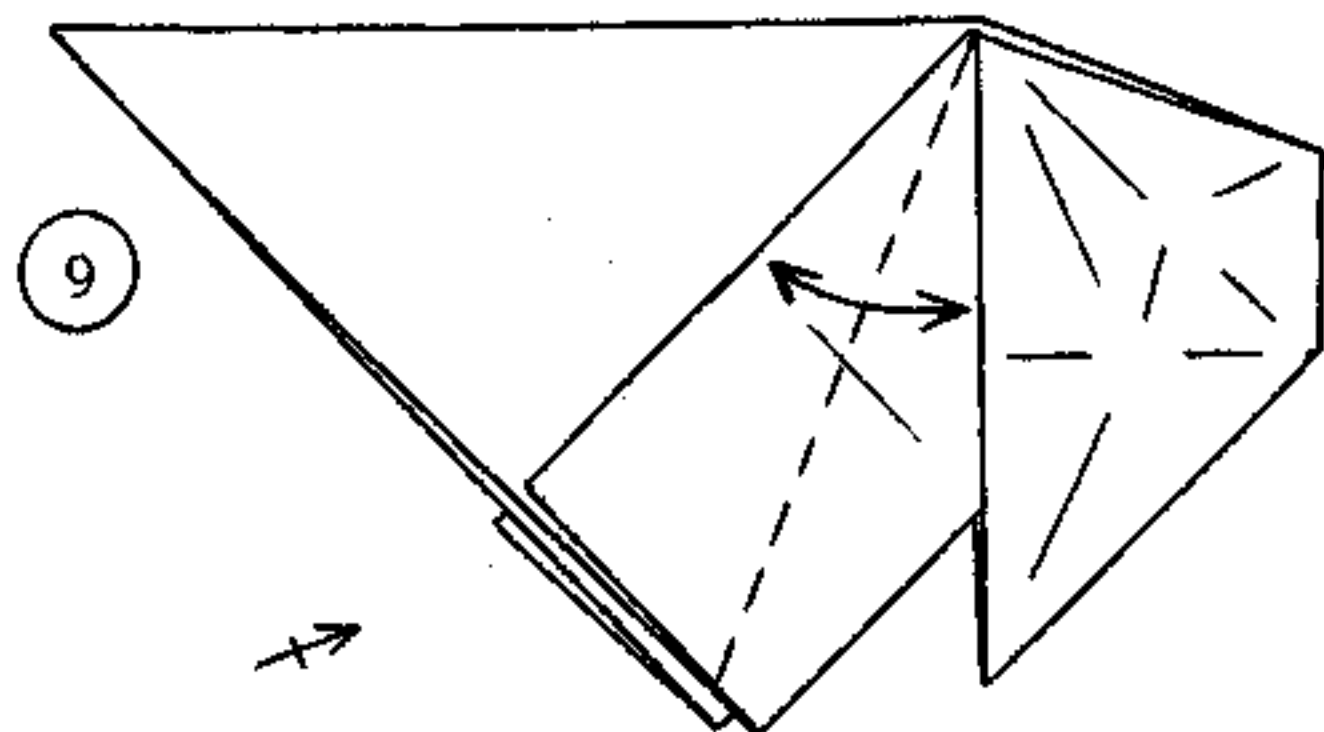

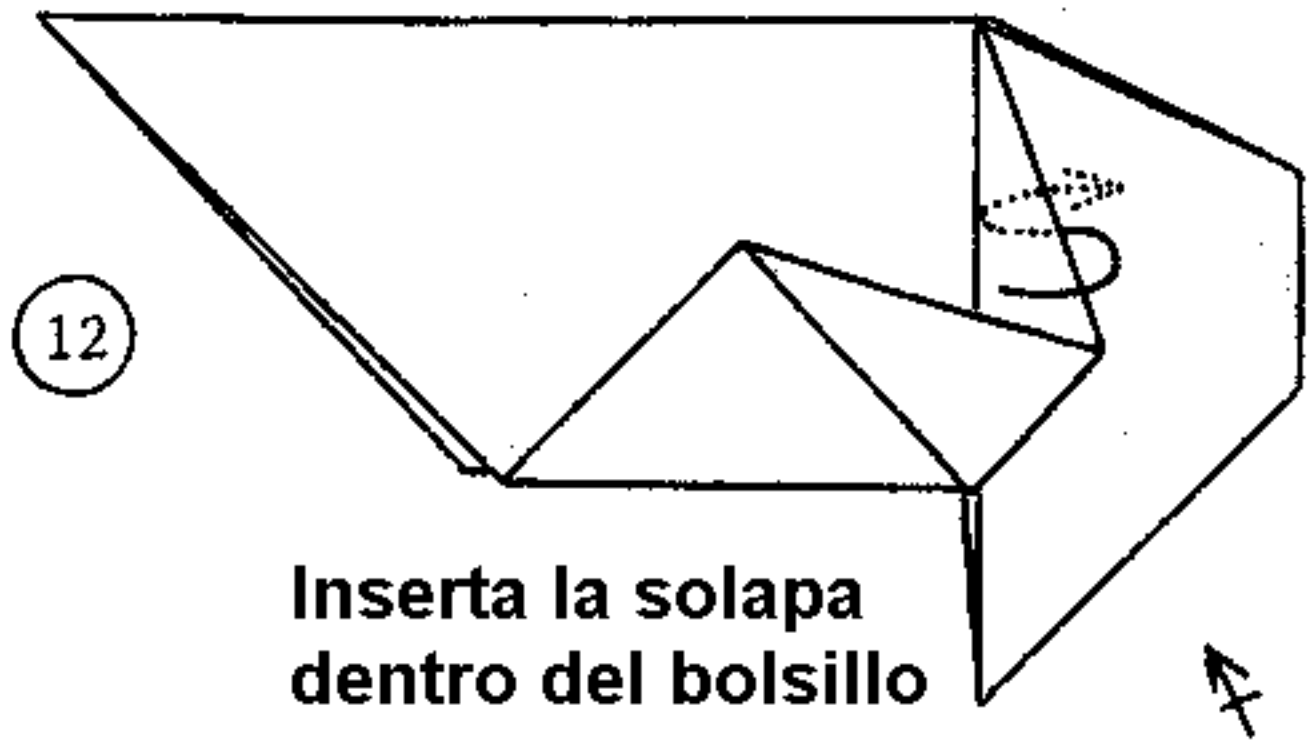
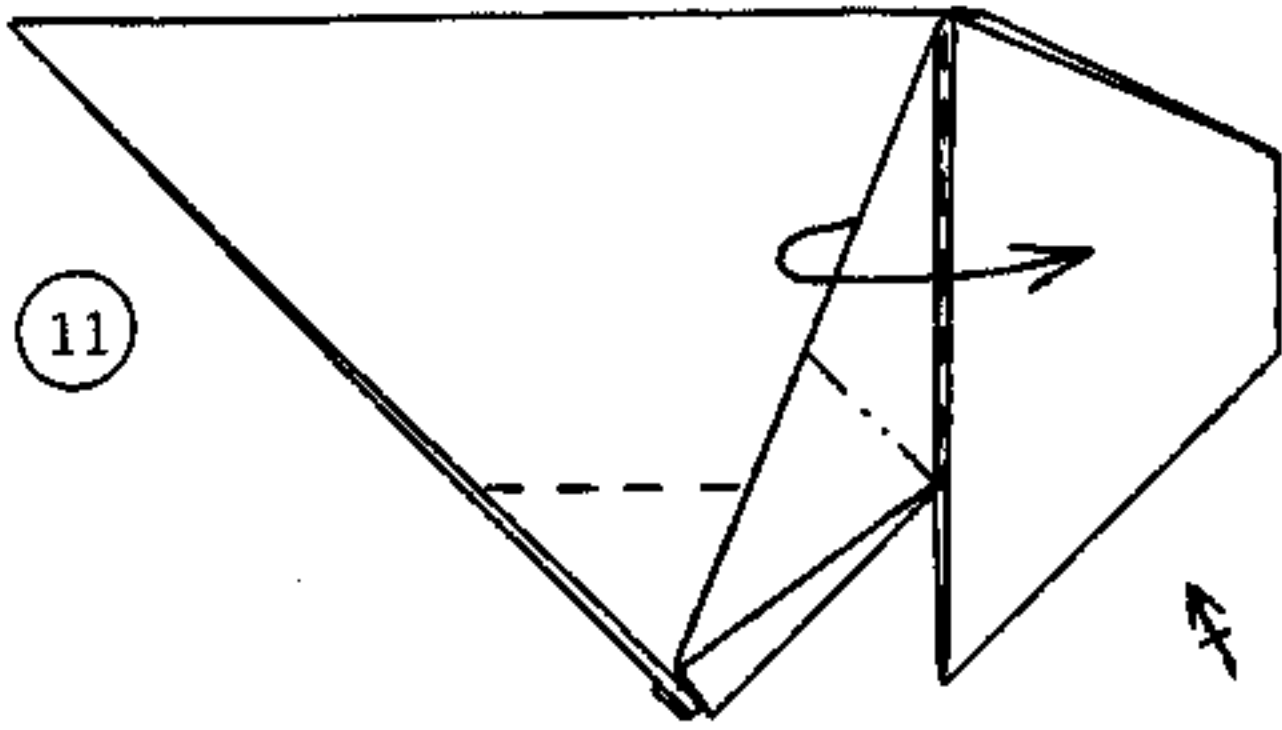

Inserta la solapa dentro del bolsillo

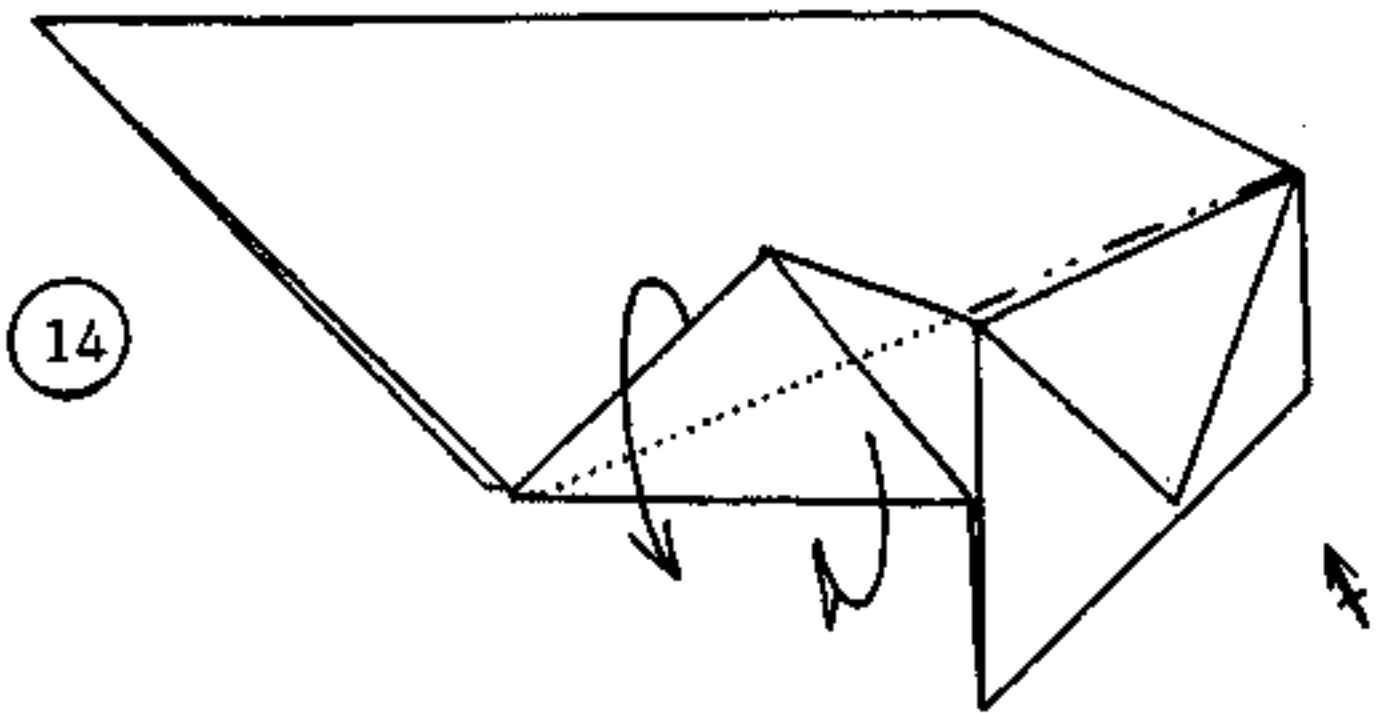
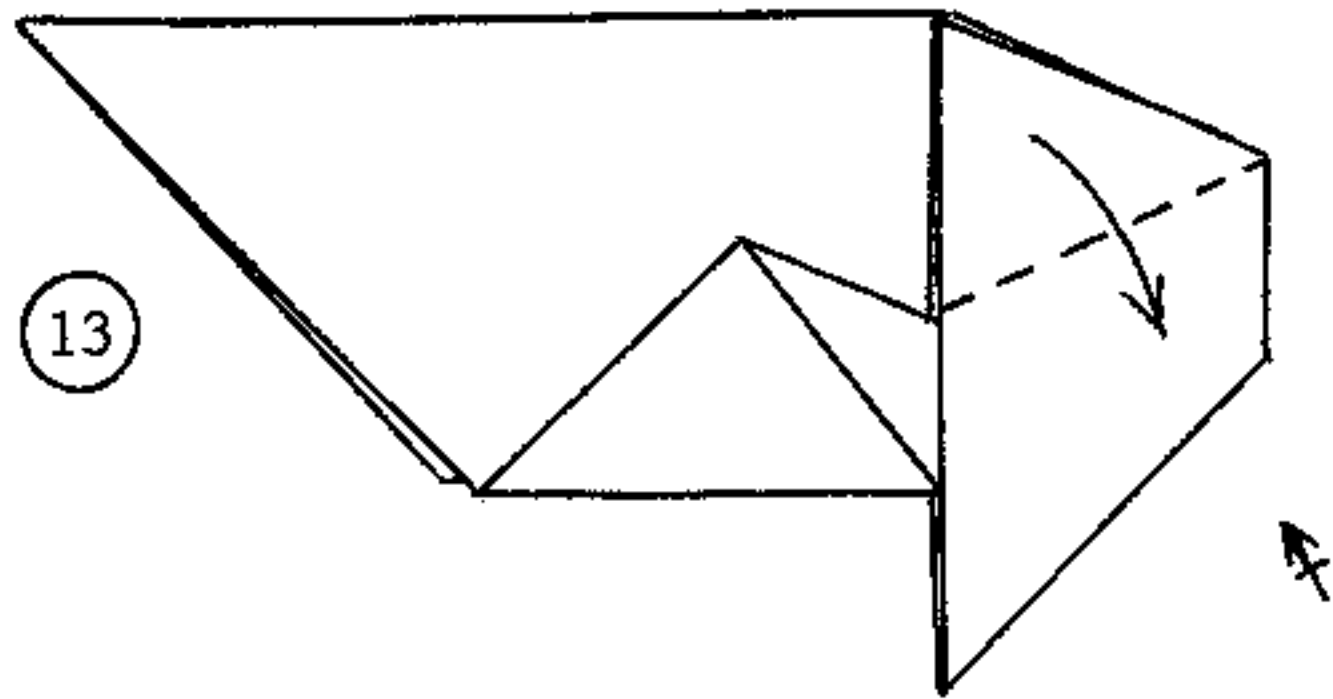

Girar hacia delante la pata trasera (Los pasos 13 y 14 se pueden combinar en un sólo movimiento)

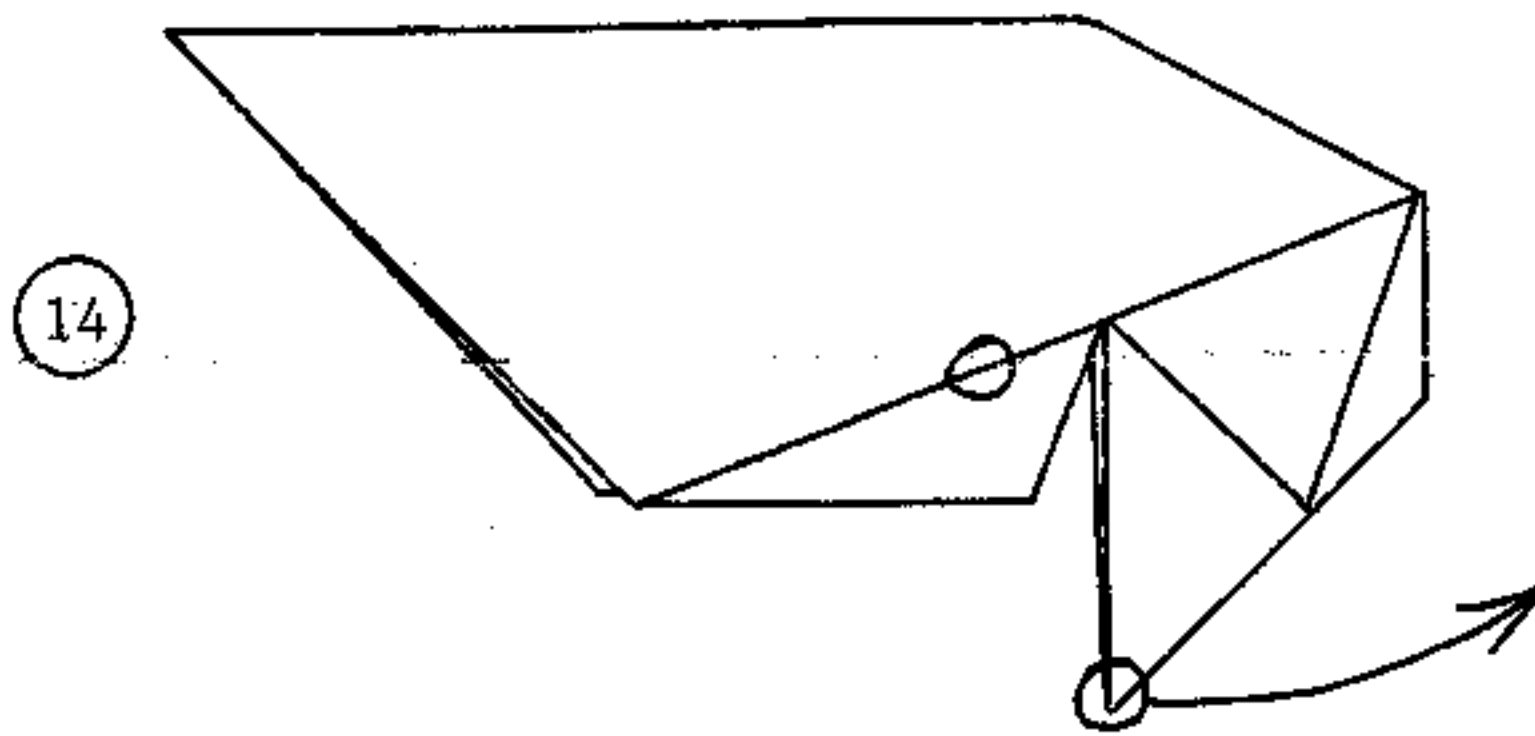

Agarrar como se muestra y separar. El modelo adquiere tridimensionalidad.

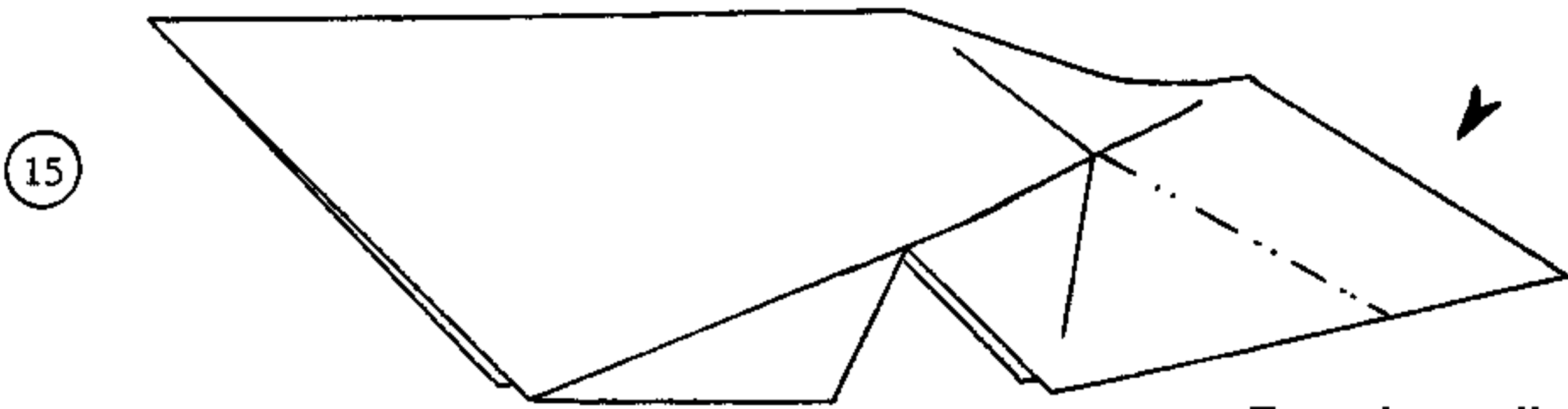

Empujar y alisar.

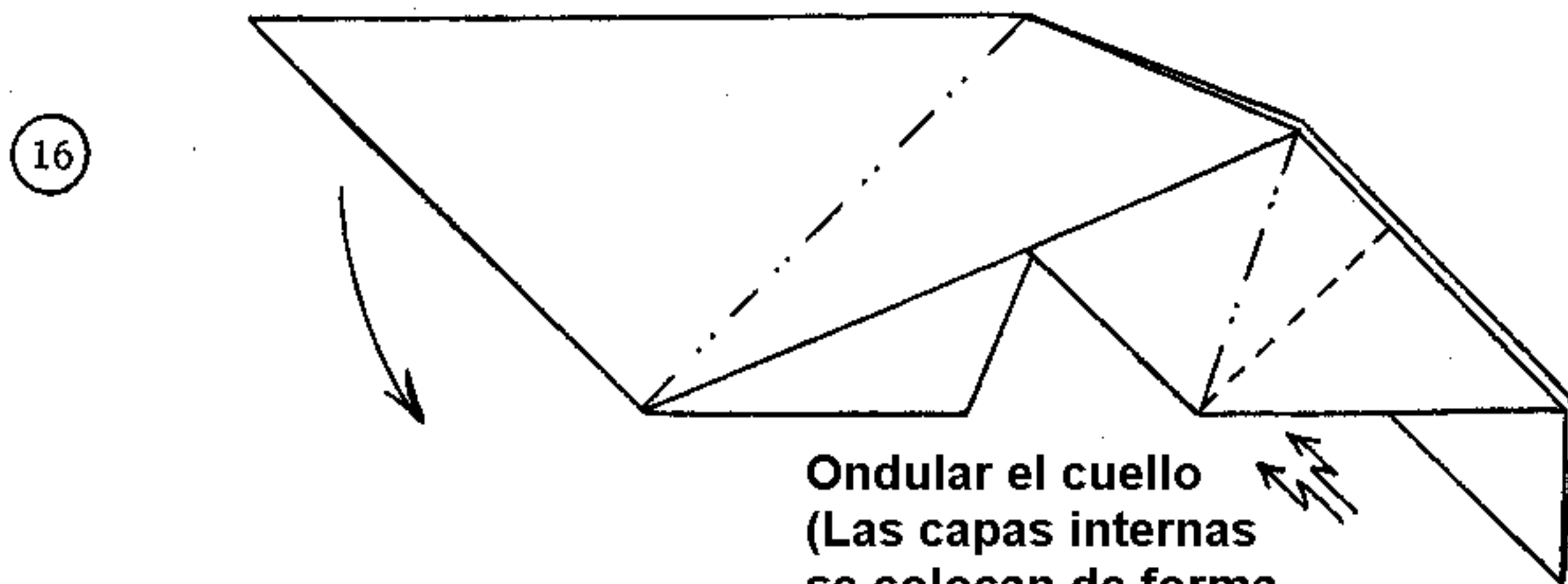

Ondular el cuello (Las capas internas se colocan de forma asimétrica)

17

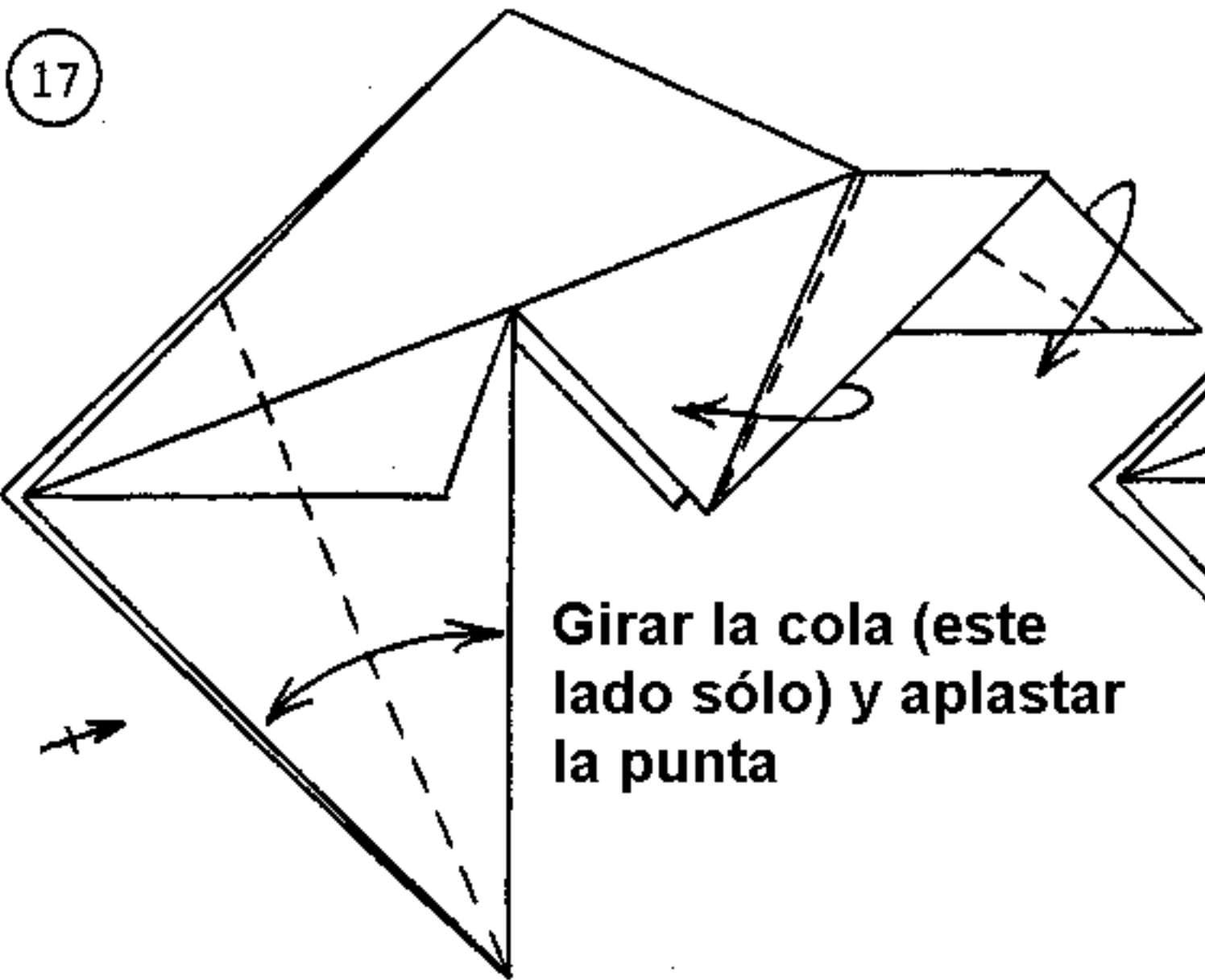

Girar la cola (este lado sólo) y aplastar la punta

18

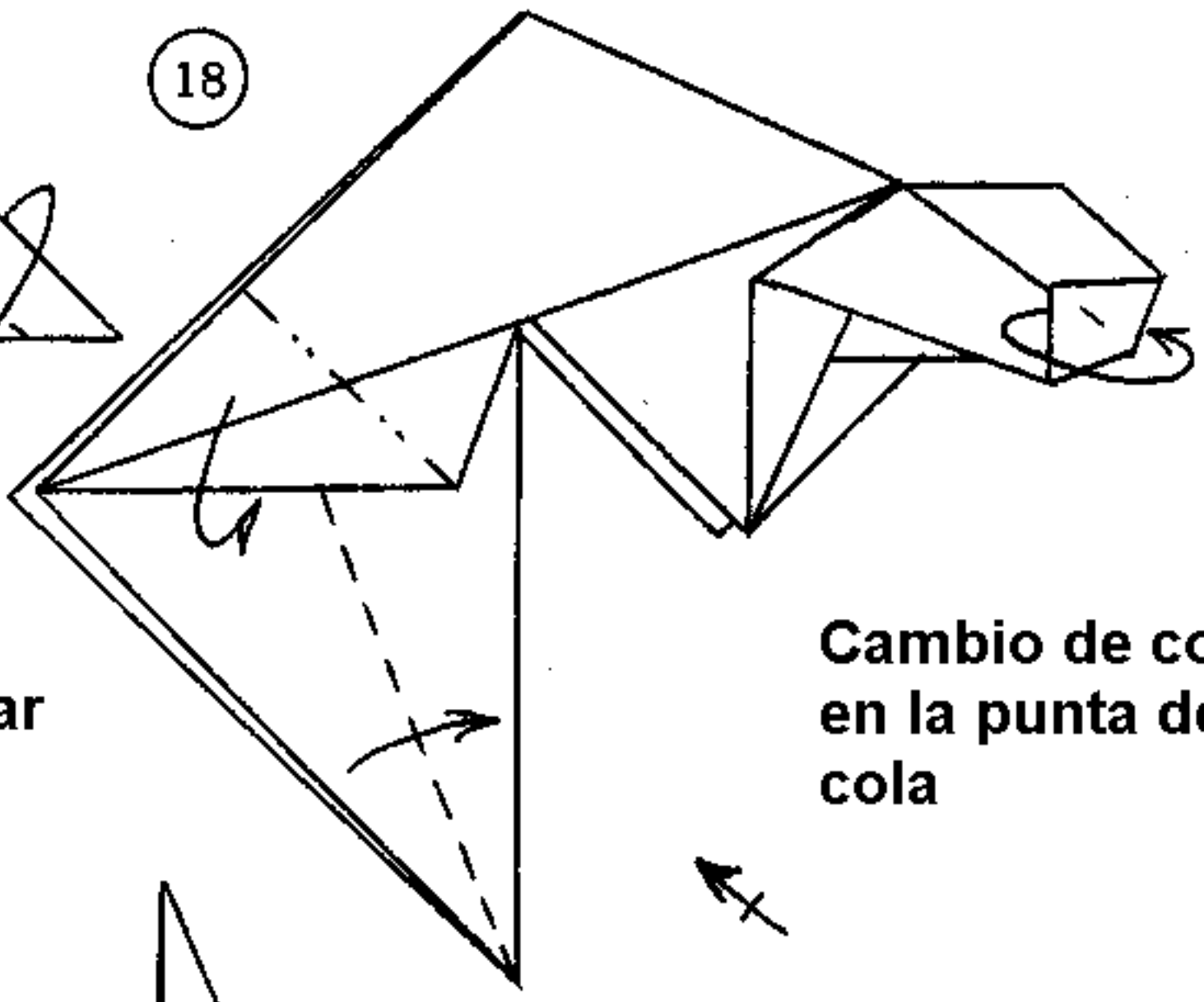

Cambio de color en la punta de la cola

19

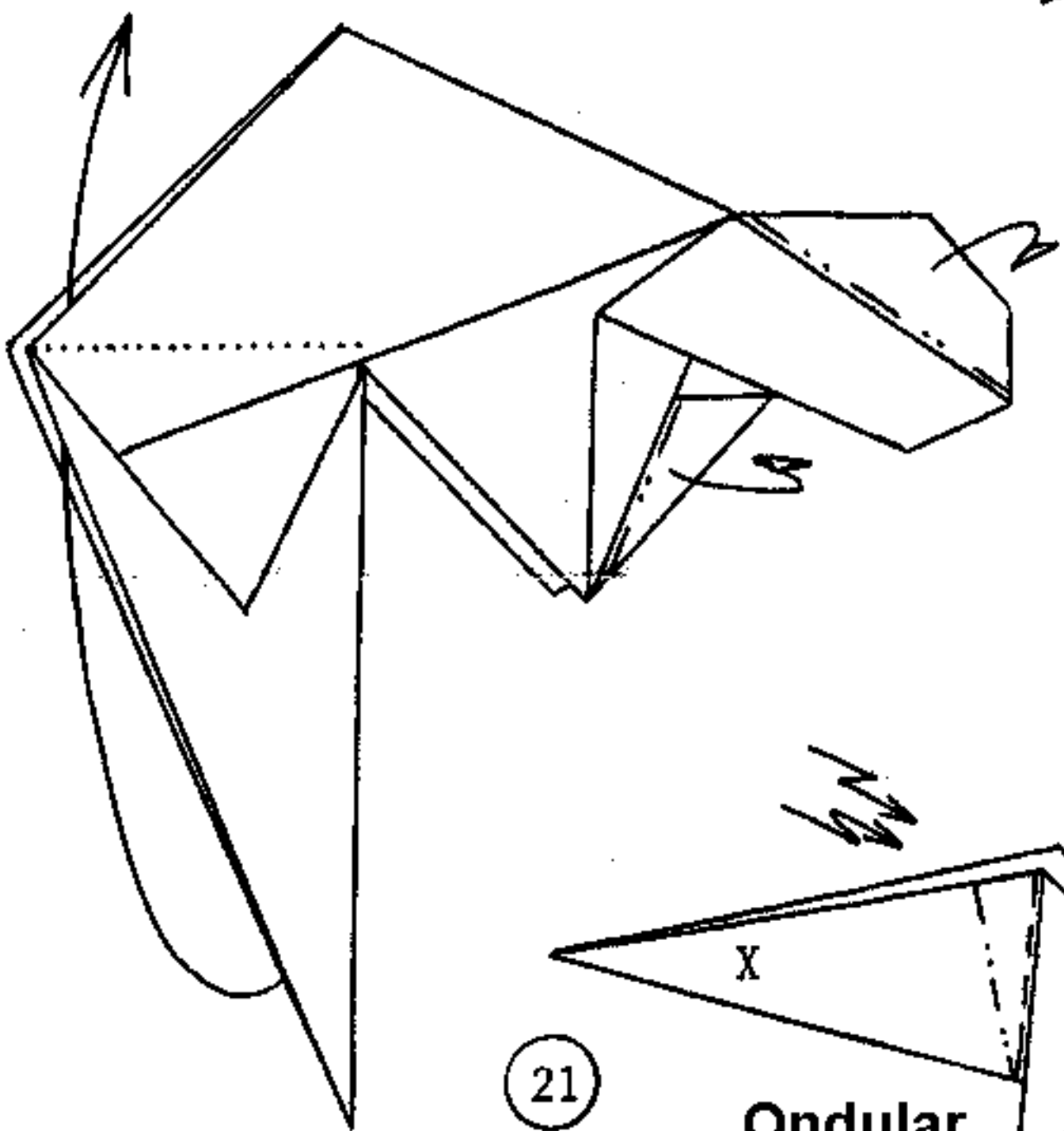

20

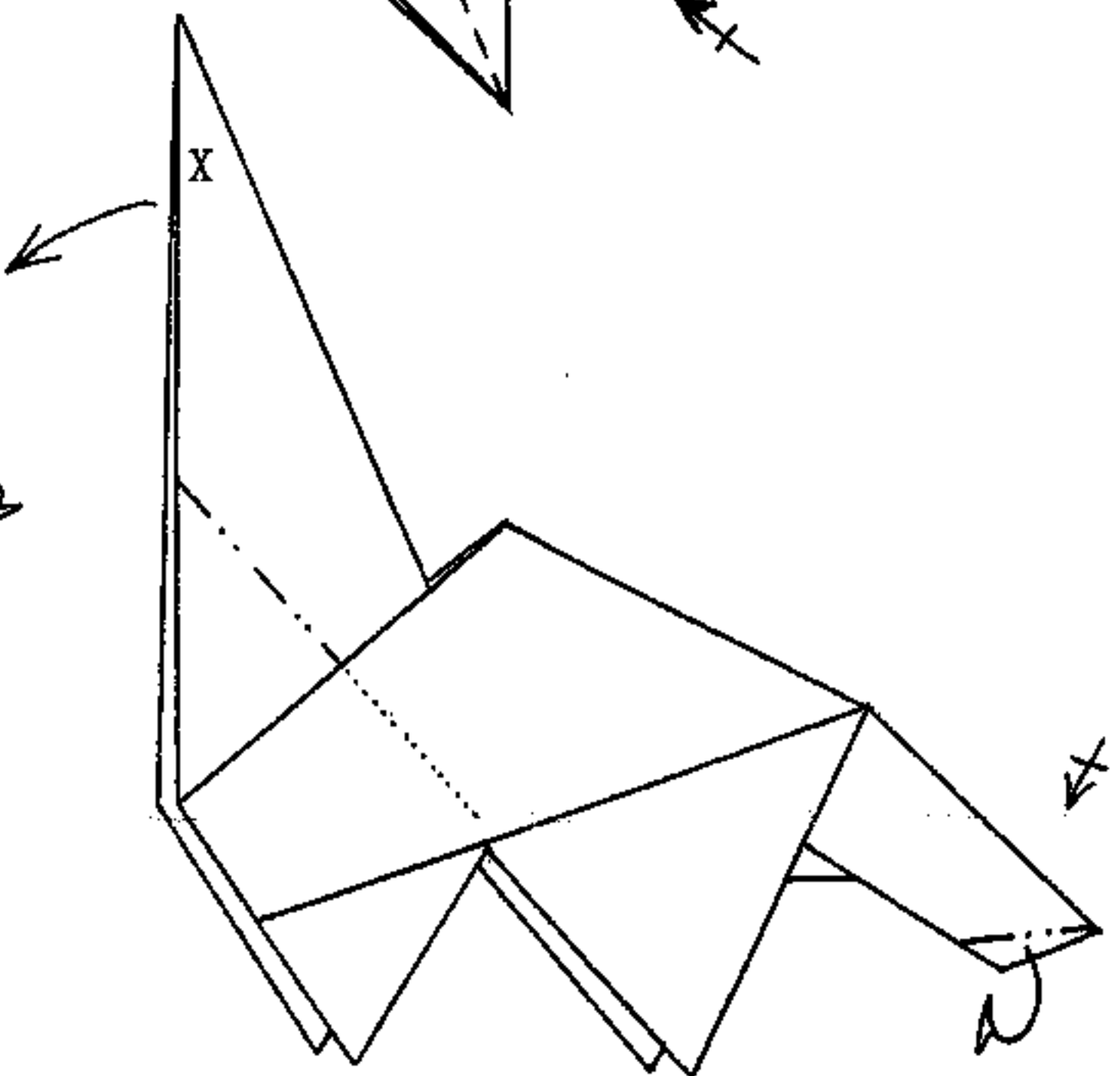

21

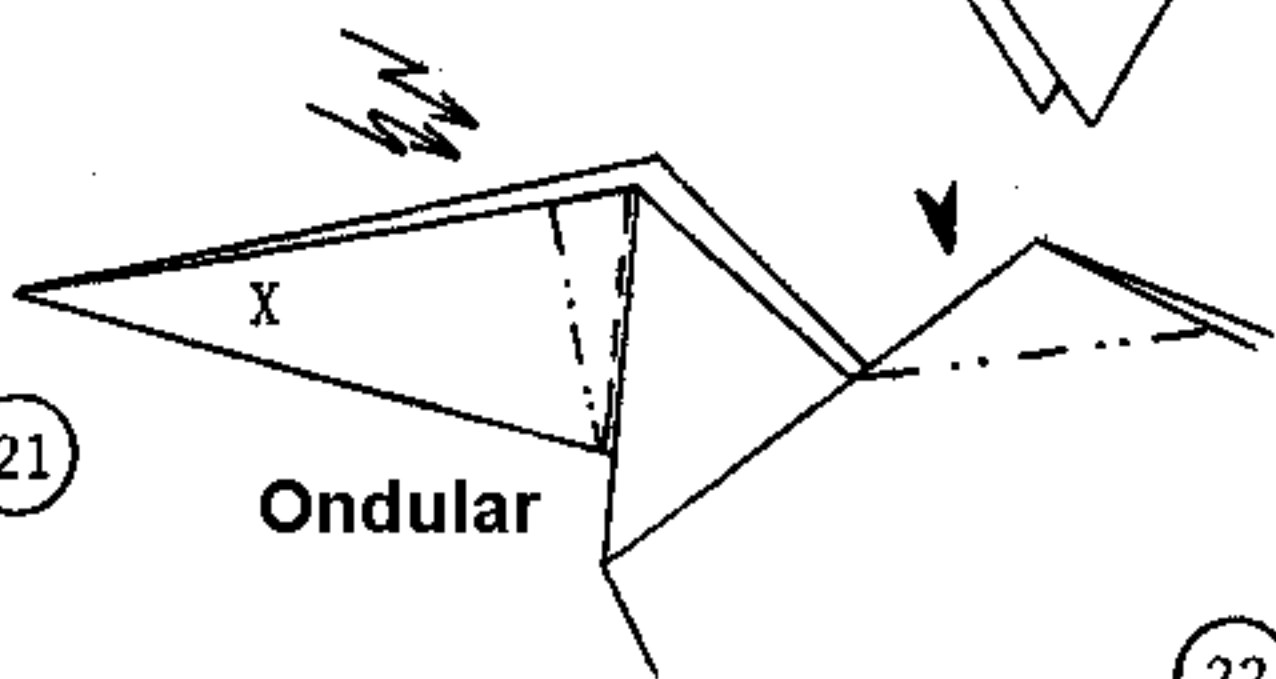

Ondular

22

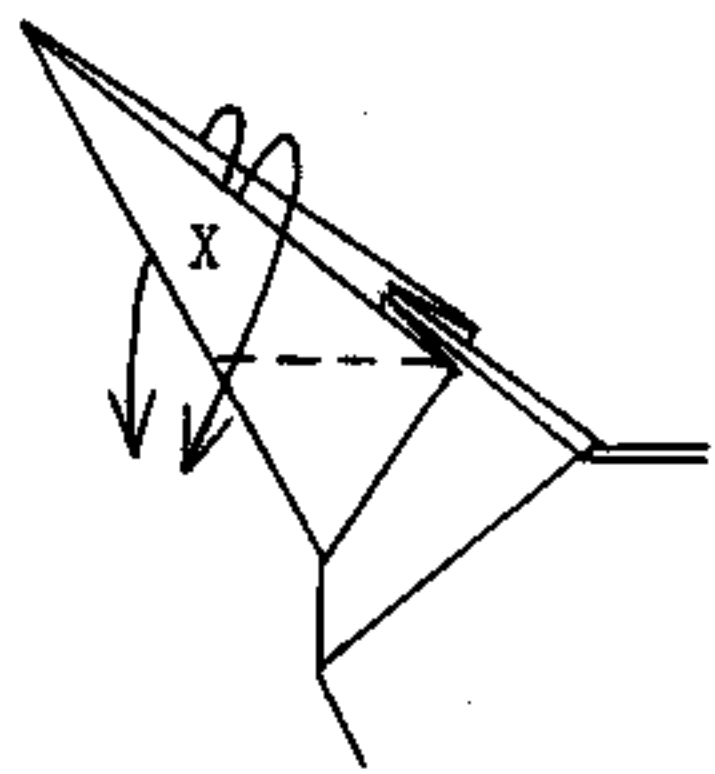

23

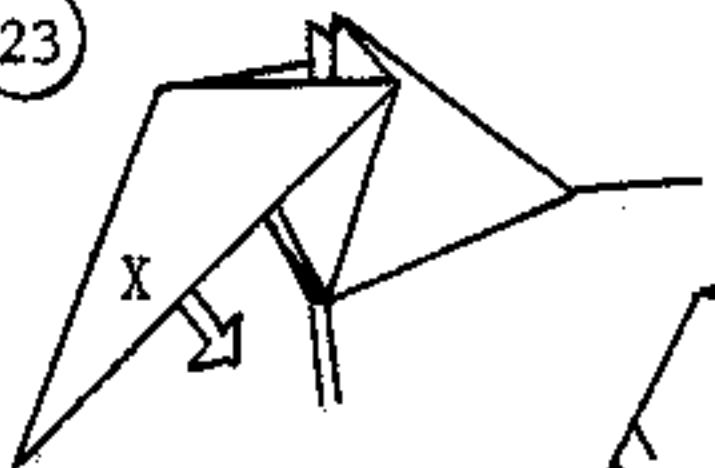

24

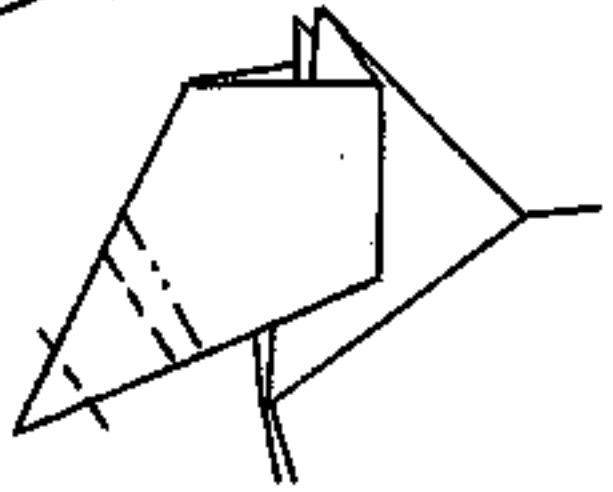

26

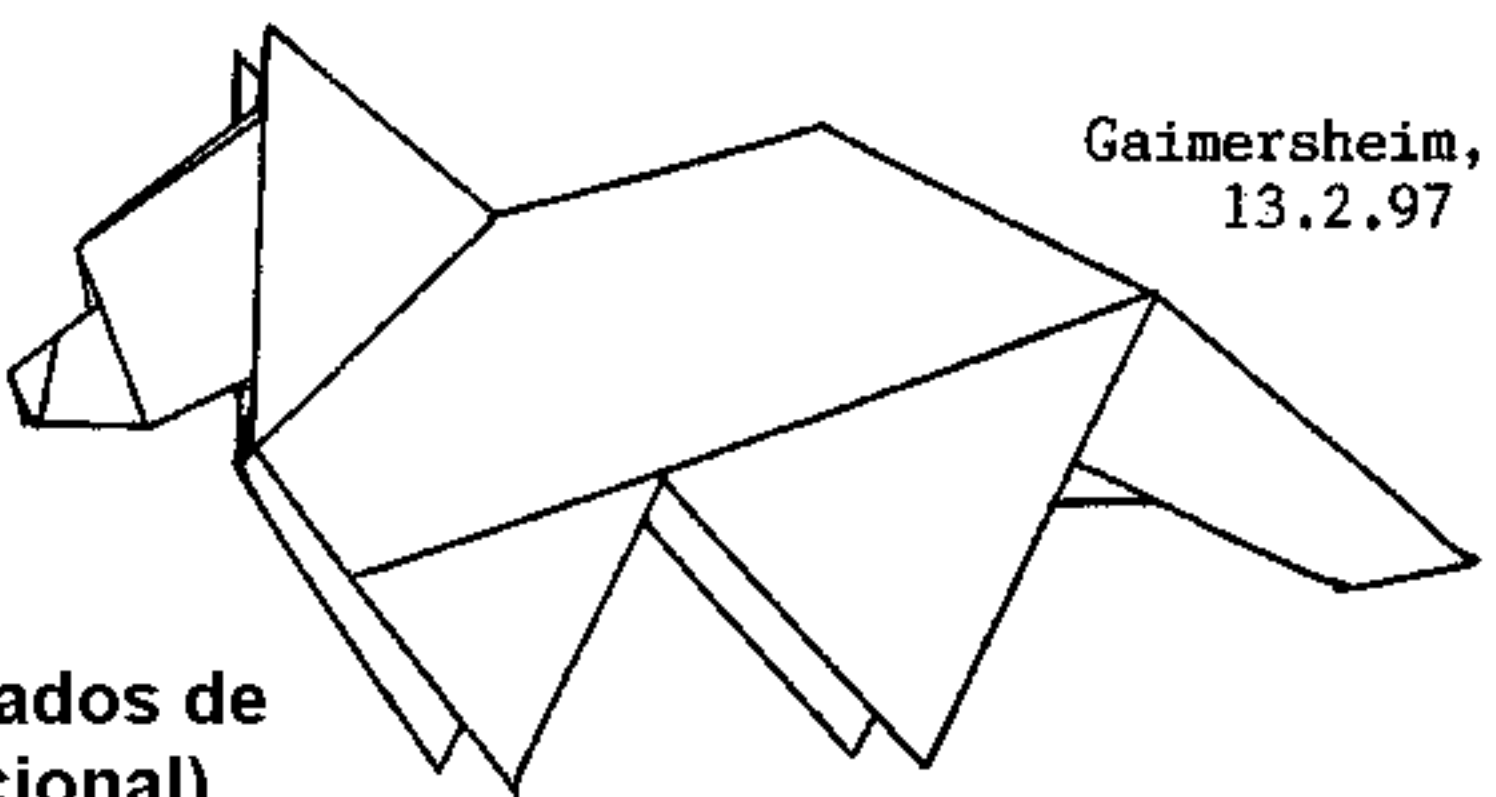

Gaimersheim, 13.2.97

25



Envolver los lados de la cabeza (opcional)