

# BUFFLE

**Niveau de difficulté :** Intermédiaire.

**Carré couleur :** Recto

**Format :** 30 cm

**Modèle terminé :** 12 cm

**Papier :** 80 g

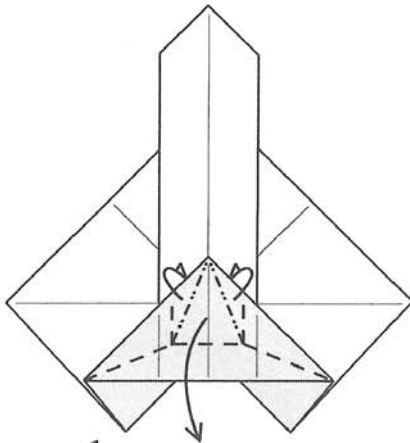

**1**  
Plis pivots.

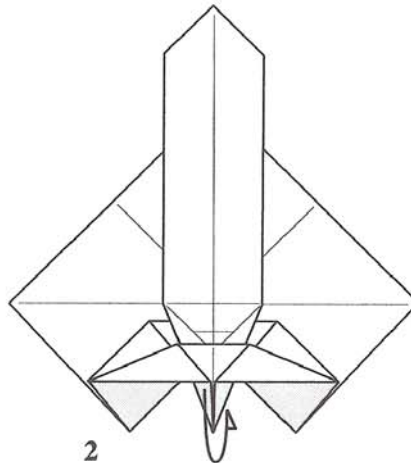

**2**  
Basculer la queue derrière.

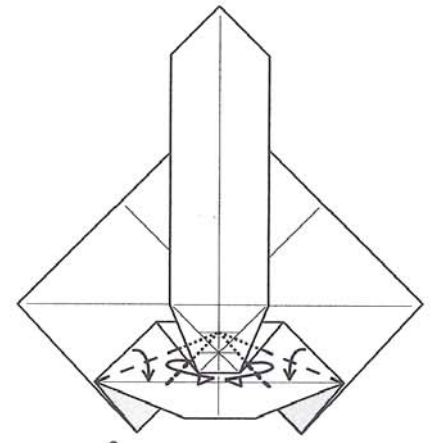

**3**  
Replis.

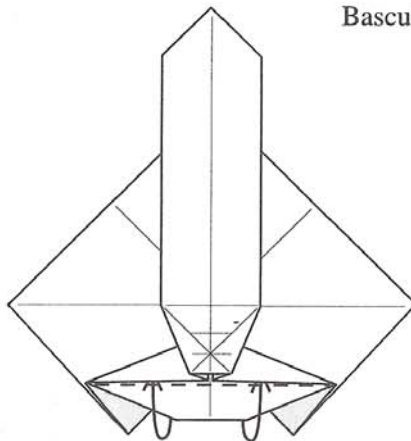

**4**  
Insérer dans la poche.

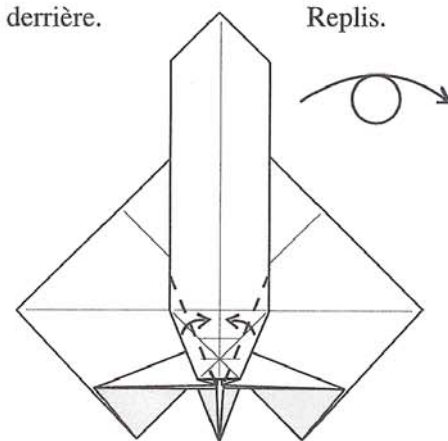

**5**  
Plis vallées.  
Retourner le modèle.

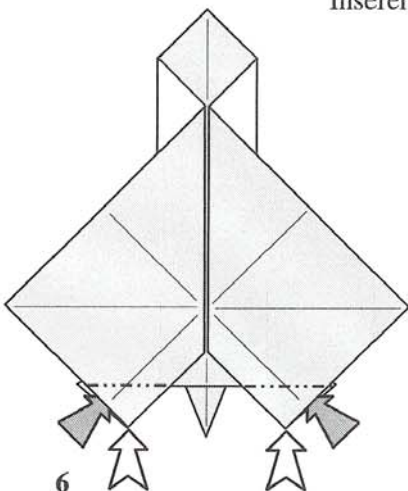

**6**  
Plis inversés.

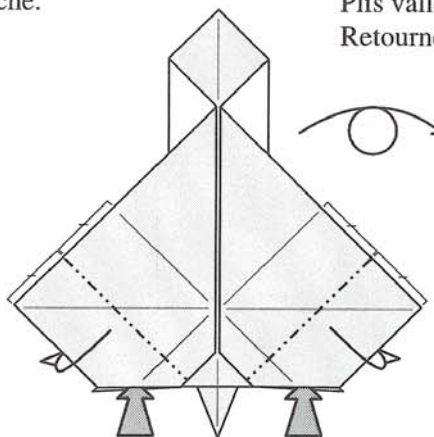

**7**  
Plier derrière.  
Retourner le modèle.

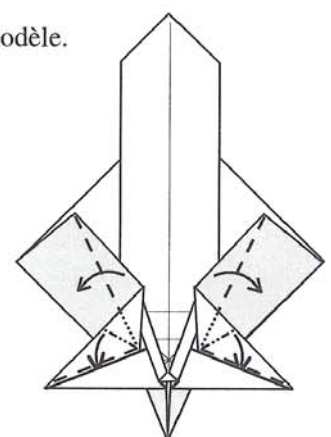

**8**  
Insérer dans les poches.

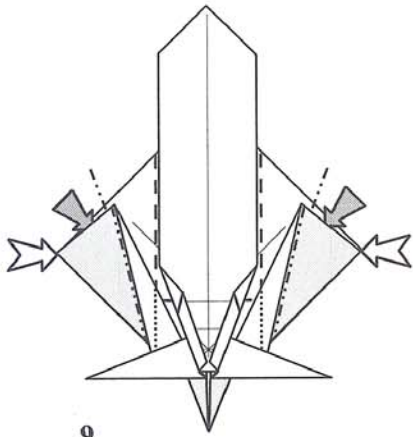

**9**  
Plis inversés.

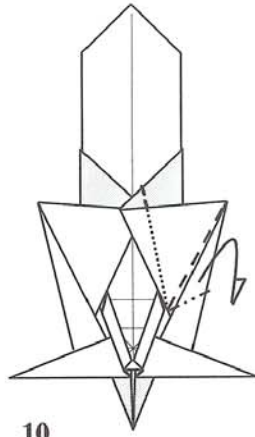

**10**  
Dégager une patte.

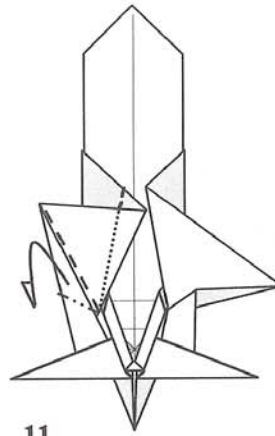

**11**  
Répéter l'étape 10 à gauche.

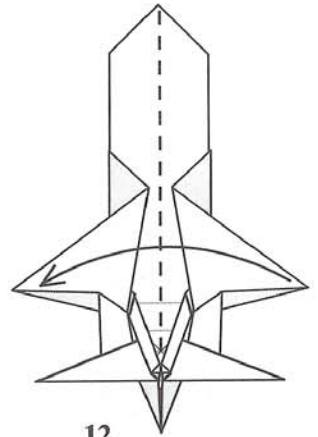

**12**  
Fermer le modèle.

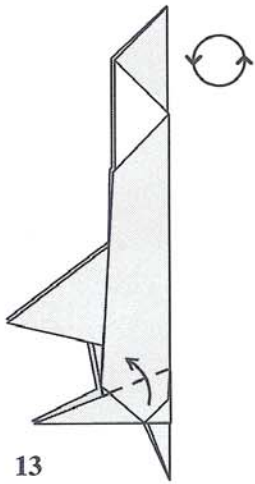

**13**  
Pli vallée.  
Rotation du modèle.  
Répéter derrière.

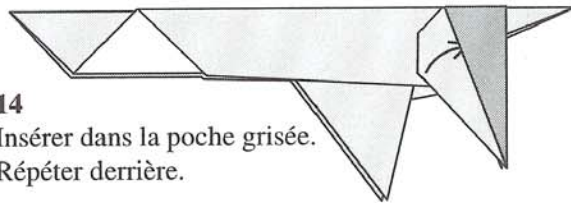

**14**  
Insérer dans la poche grisée.  
Répéter derrière.

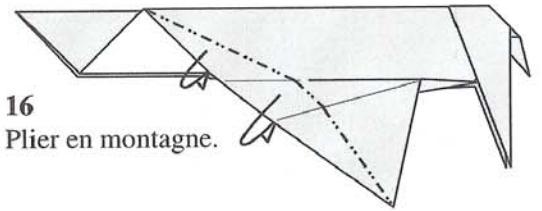

**16**  
Plier en montagne.

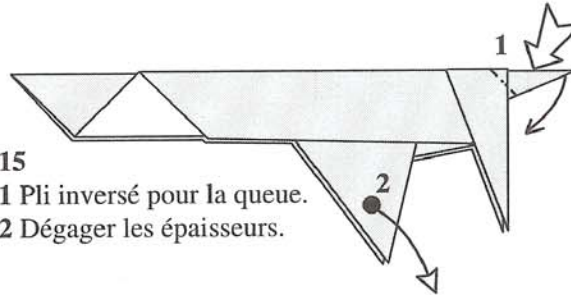

**15**  
1 Pli inversé pour la queue.  
2 Dégager les épaisseurs.

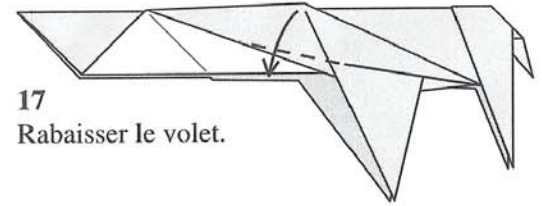

**17**  
Rabaisser le volet.

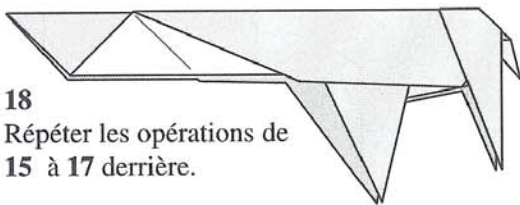

**18**  
Répéter les opérations de  
15 à 17 derrière.

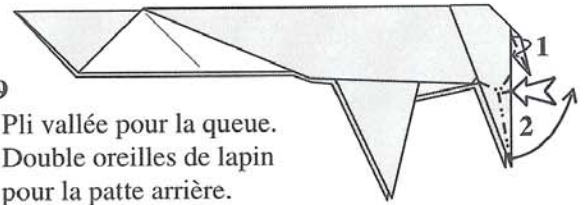

**19**  
1 Pli vallée pour la queue.  
2 Double oreilles de lapin  
pour la patte arrière.  
Répéter derrière.

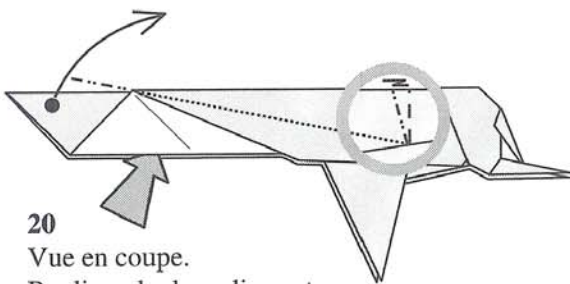

**20**  
Vue en coupe.  
Repli sur le dos, pli montagne  
pour relever la pointe.

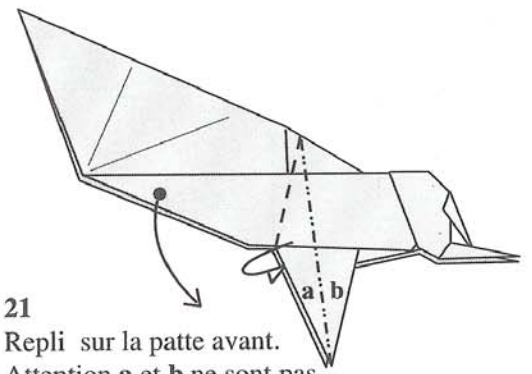

**21**  
Repli sur la patte avant.  
Attention **a** et **b** ne sont pas  
des angles égaux.  
Répéter derrière.

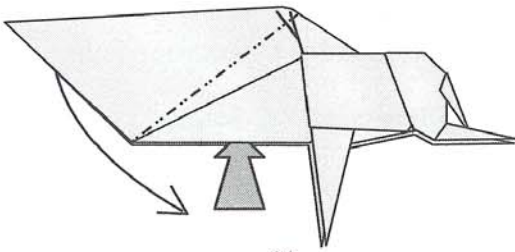

22  
Pli inversé.

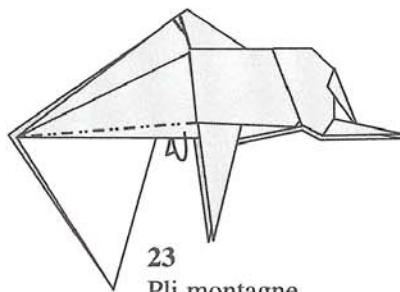

23  
Pli montagne.  
Répéter derrière.

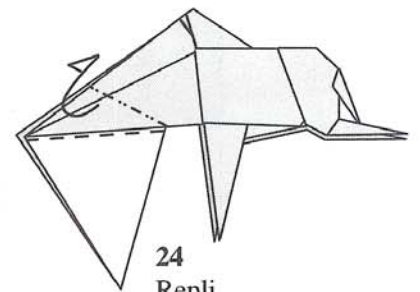

24  
Repli.  
Répéter derrière.

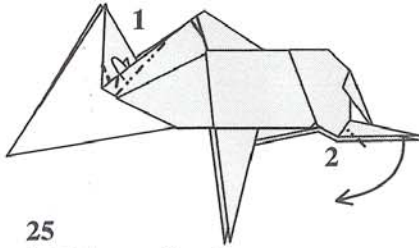

25  
1 Pli inversé intérieur.  
2 Pli inversé intérieur  
pour la patte arrière.  
Répéter derrière.

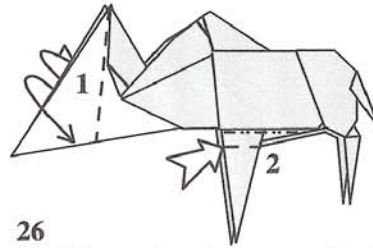

26  
1 Pli inversé extérieur pour la tête.  
2 Repli pour la patte avant.  
Répéter derrière.

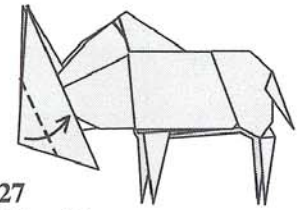

27  
Pli vallée.

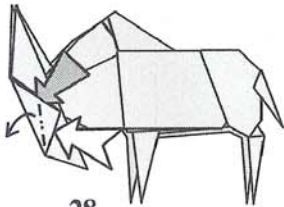

28  
Pli aplati.

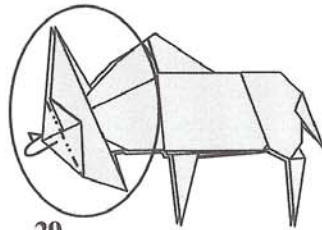

29  
Plier derrière.  
Sélection de la zone de travail.

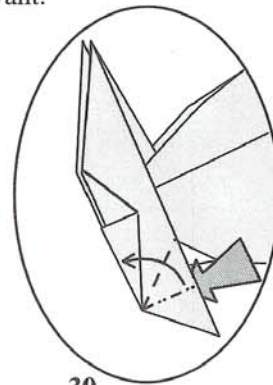

30  
Pli aplati.

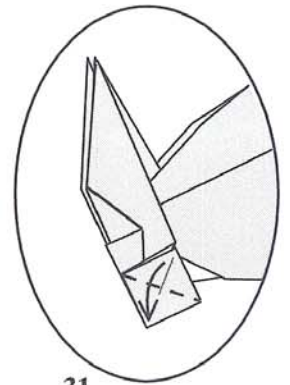

31  
Pli vallée.

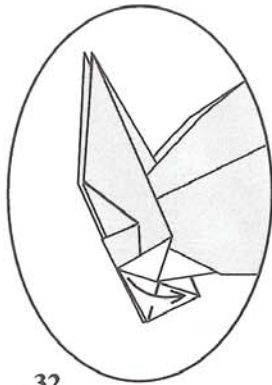

32  
Pli vallée.

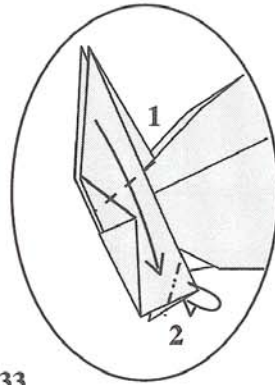

33  
1 Pli vallée pour la corne.  
2 Pli montagne pour la mâchoire.  
Répéter derrière.

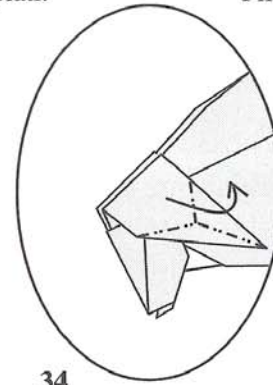

34  
Pincer et courber la corne.  
Répéter derrière.

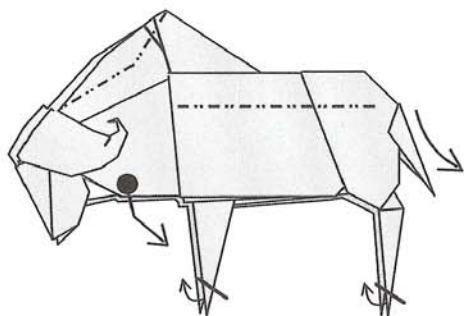

35  
Modelage final.

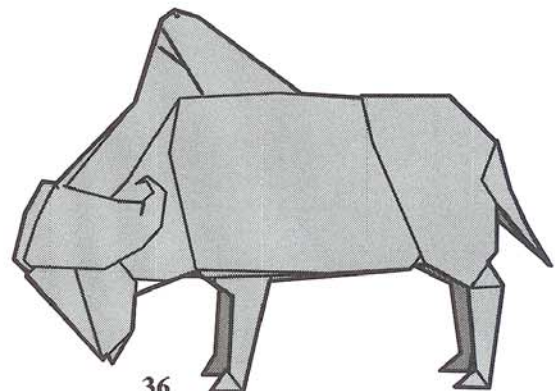

36  
BUFFLE TERMINE.