	<i>Autor:</i> Fernando Gilgado
	<i>Dificultad:</i> 
	<i>Proporción:</i> $h = 1/2 a$

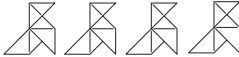

Dragón

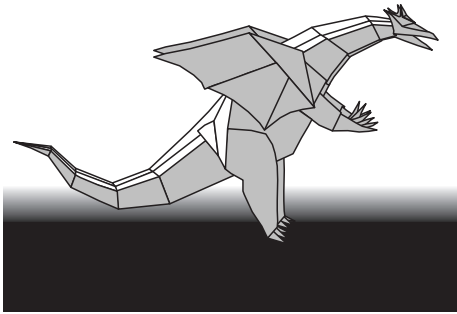

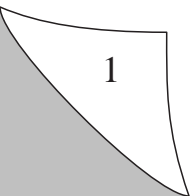
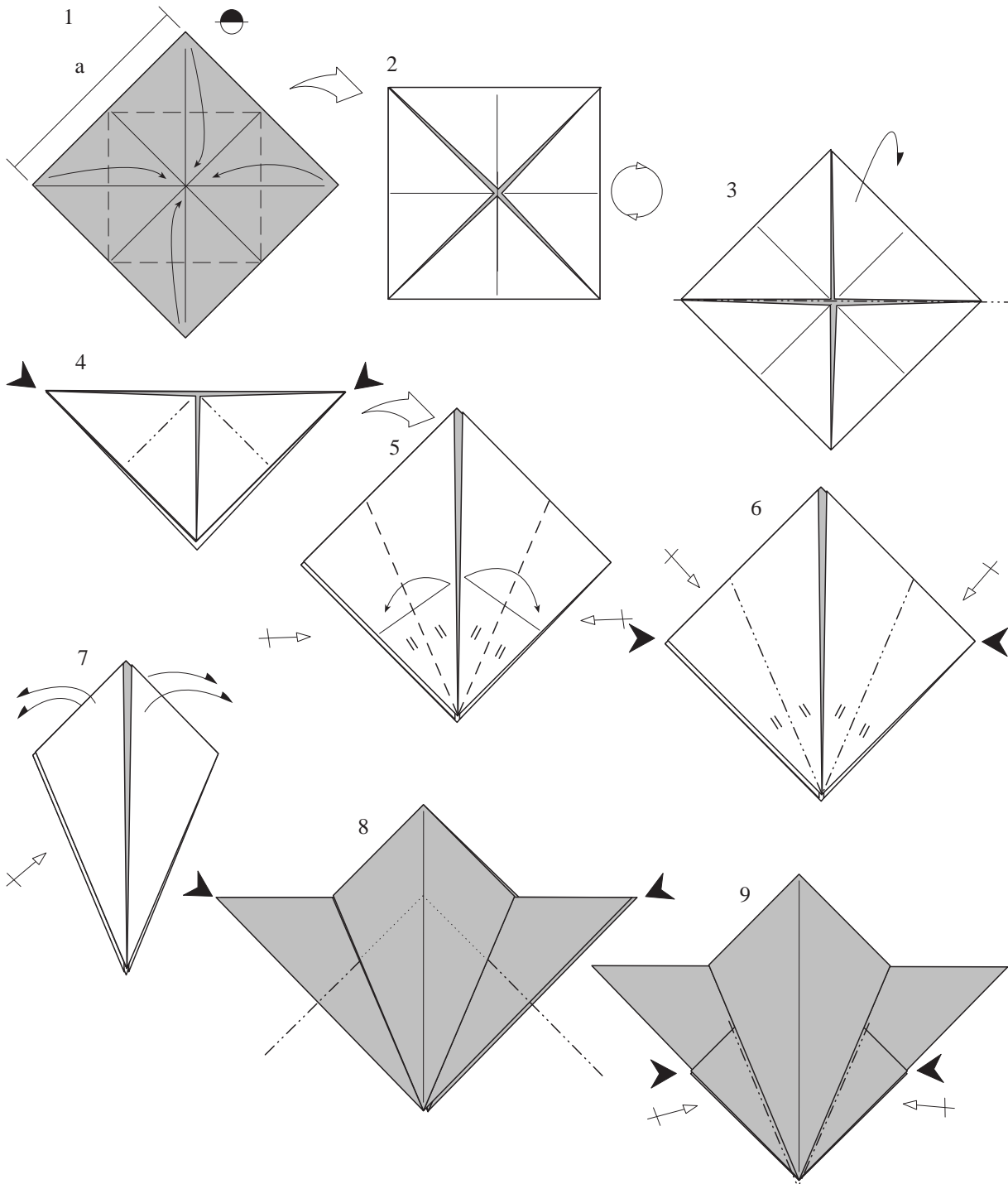
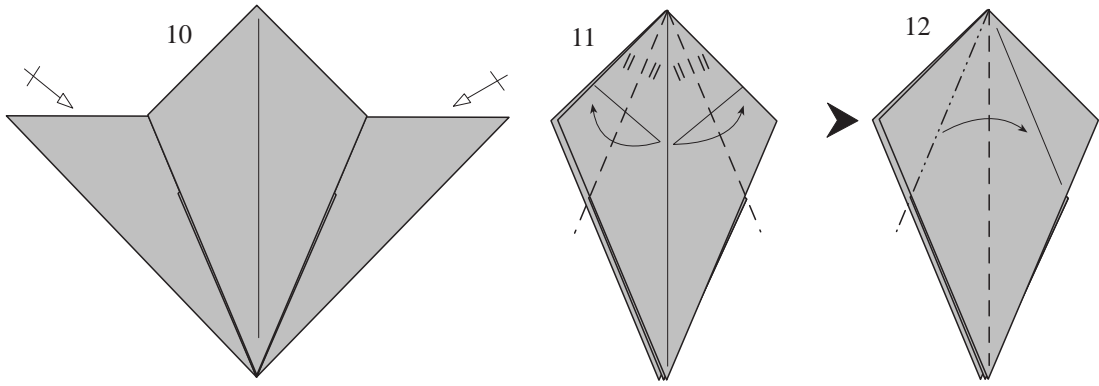

Repetir 8-9

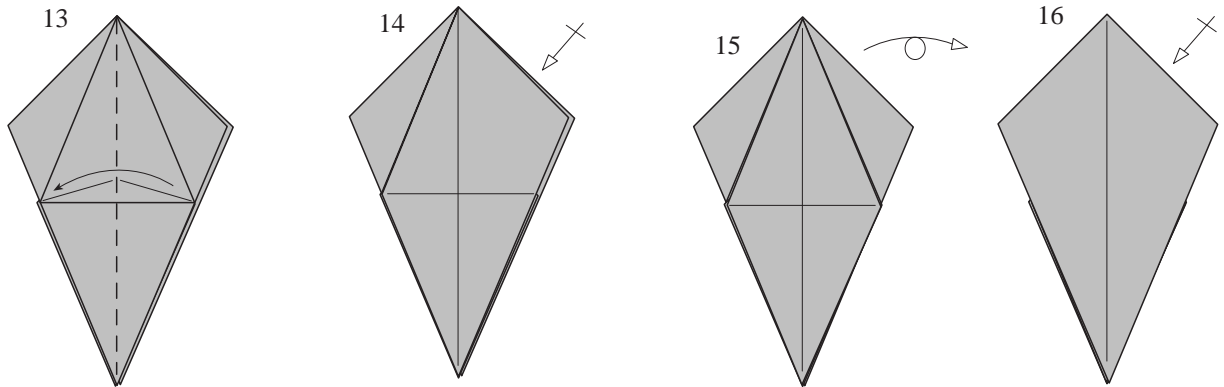

Repetir 12-13 simetricamente

Repetir 11-14

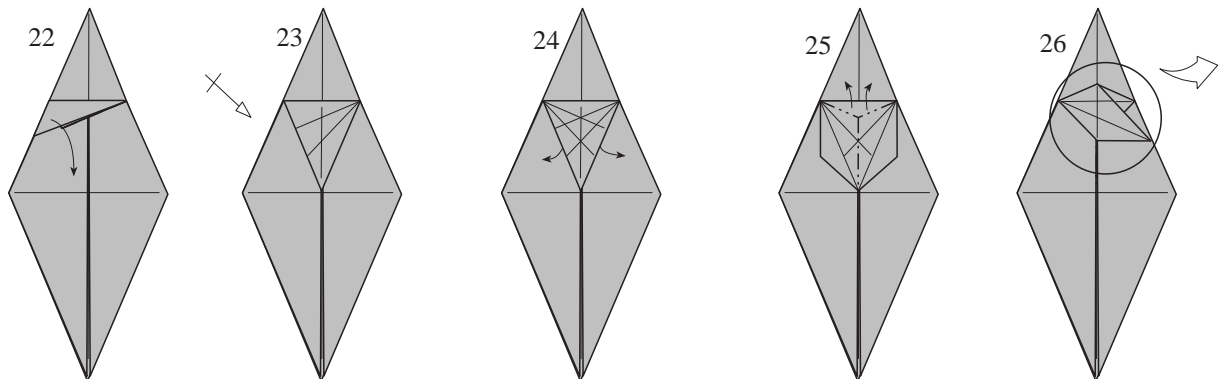
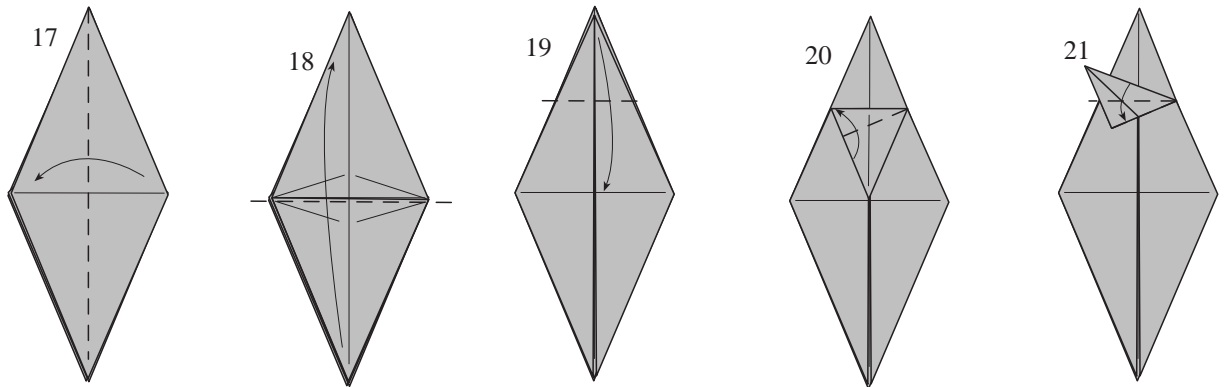

Repetir 20-22 simetricamente

Sacar

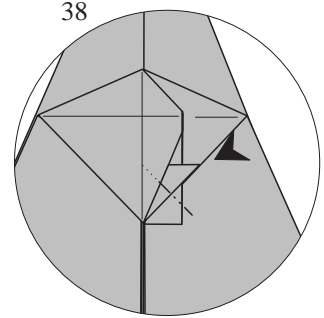
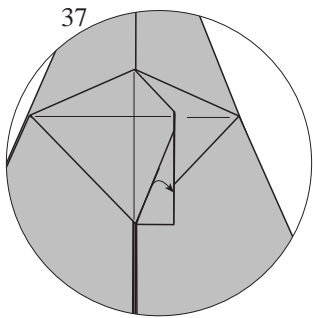
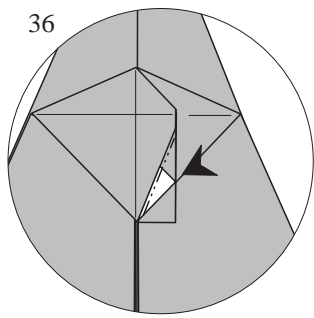
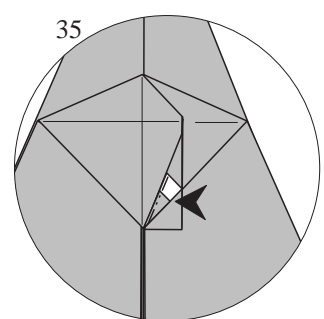
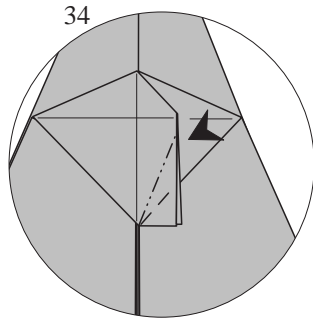
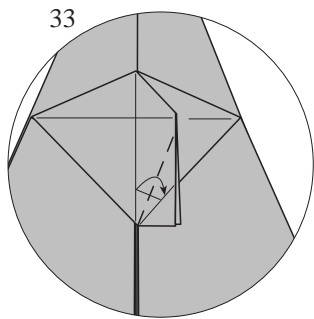
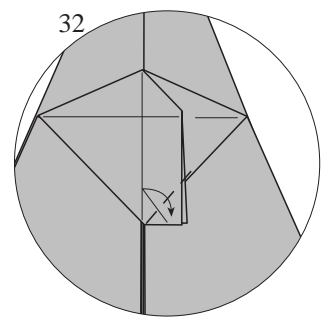
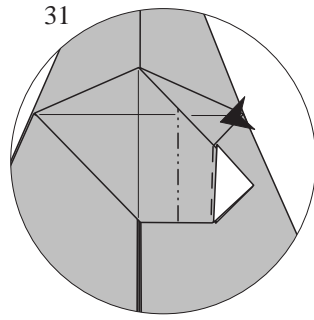
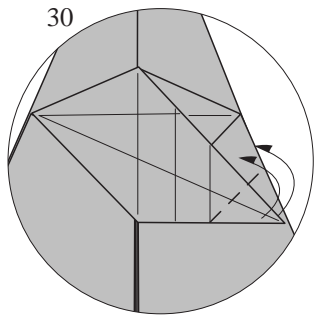
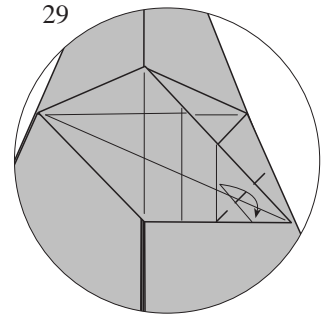
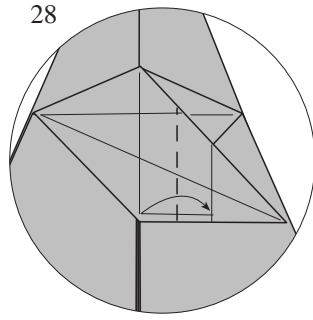
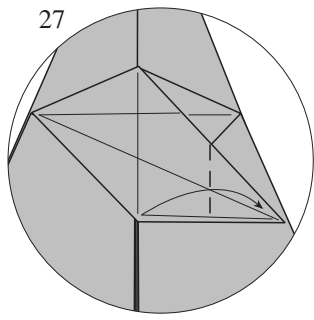

Sacar

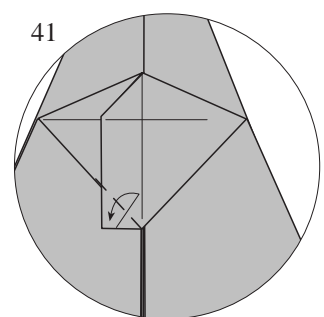
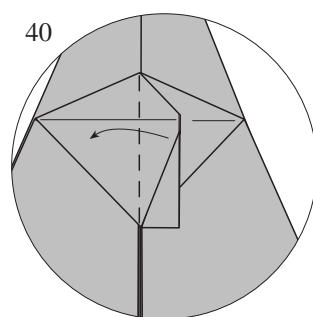
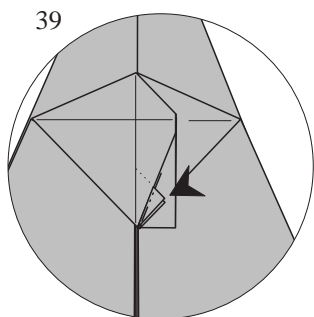

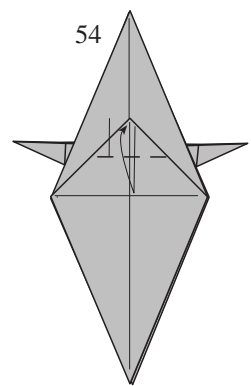
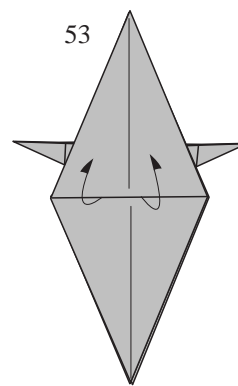
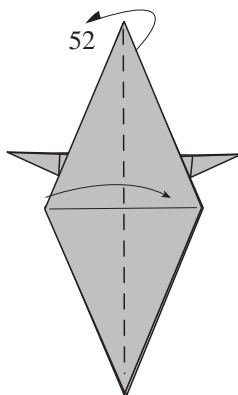
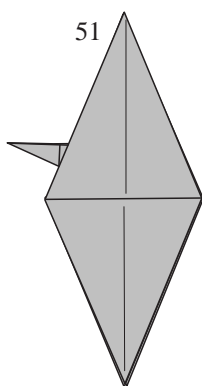
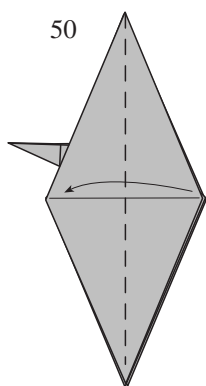
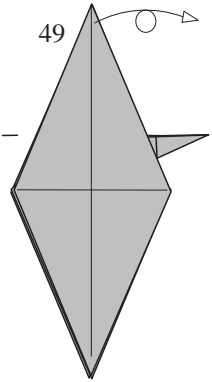
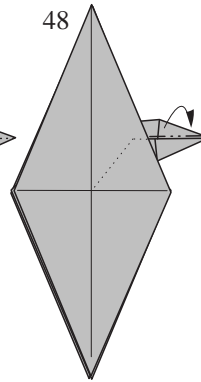
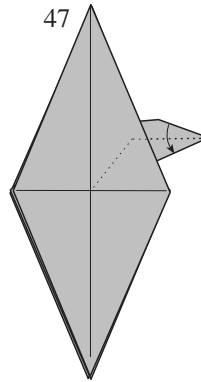
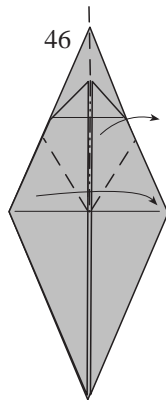
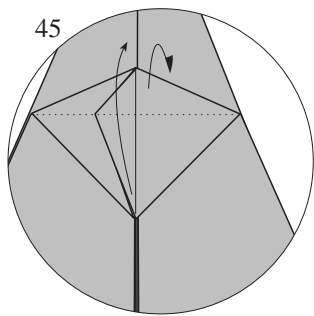
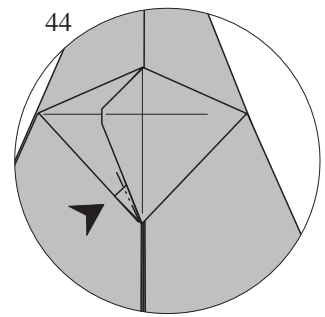
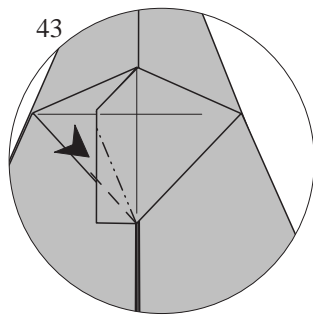
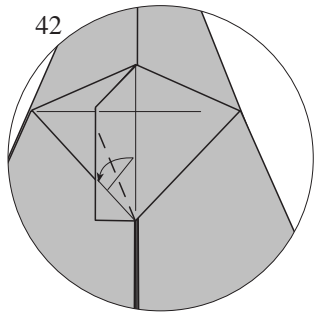

Repetir 19-48

Una solapa a la derecha y otra la izquierda

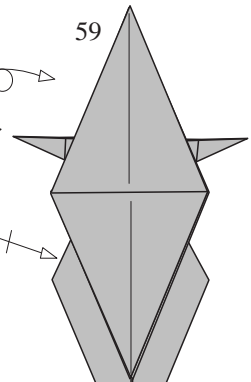
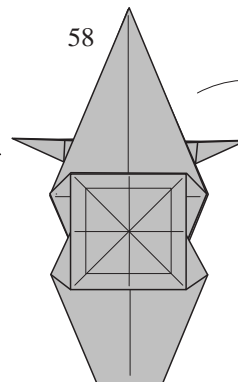
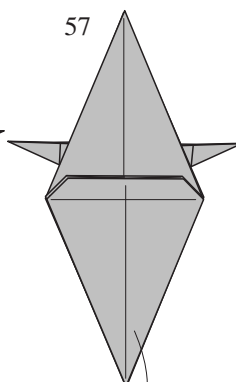
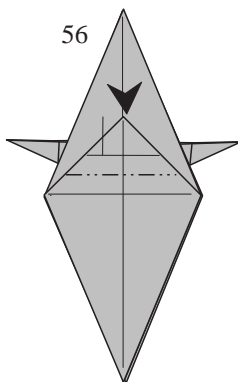
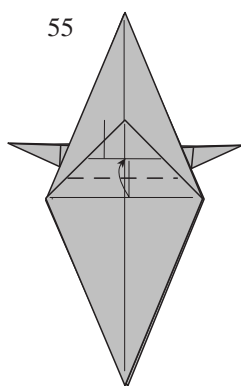

Sacar

Repetir 53-57

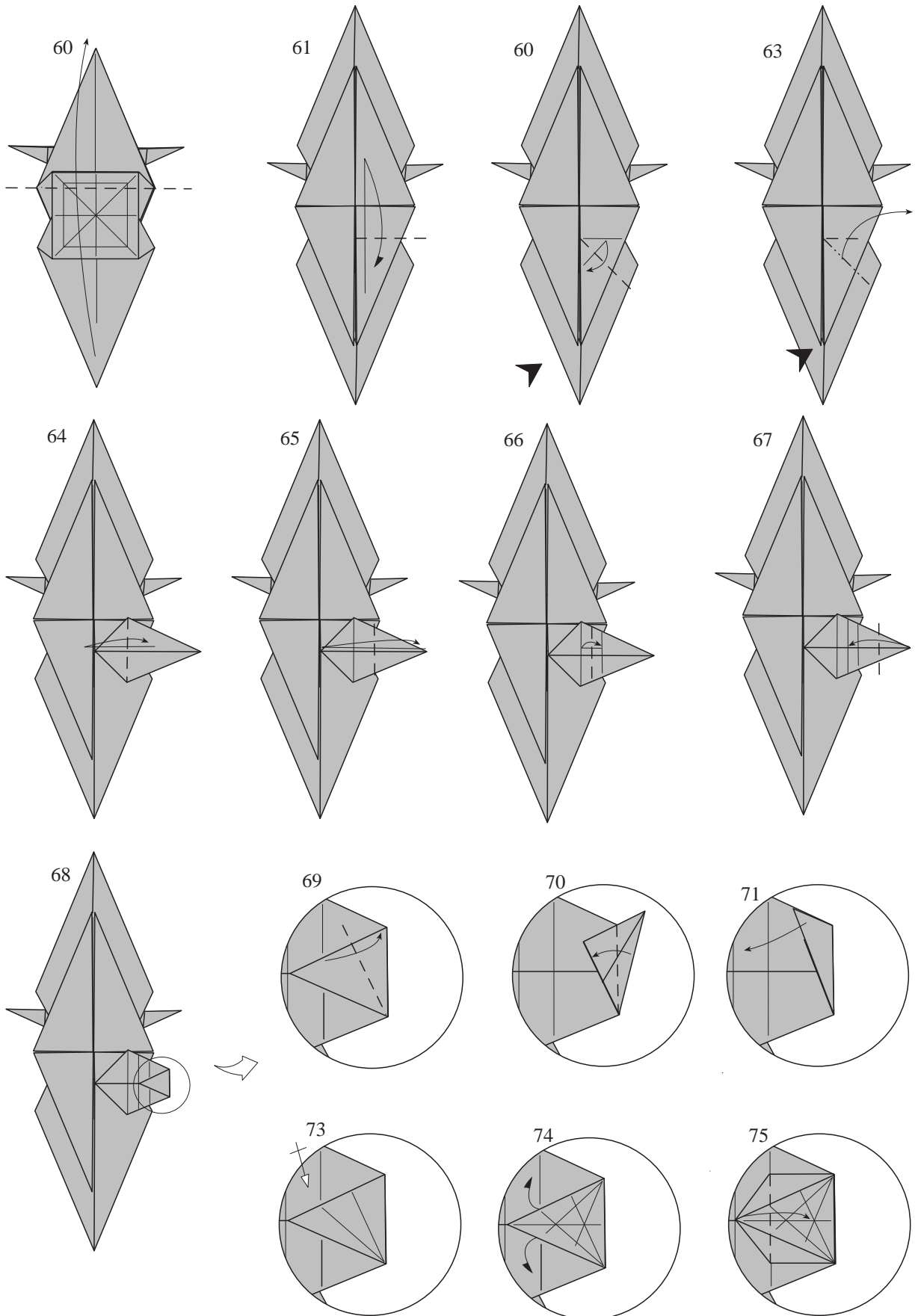

Repetir 69-71

Sacar

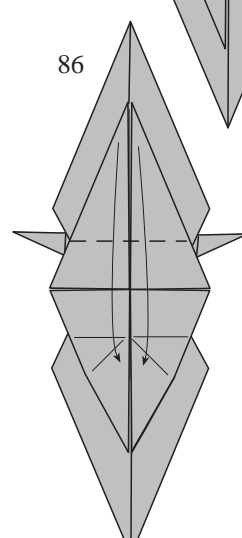
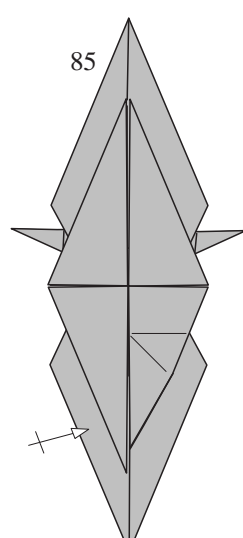
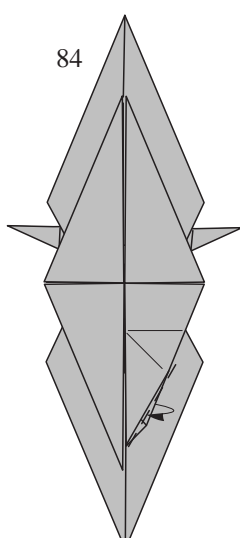
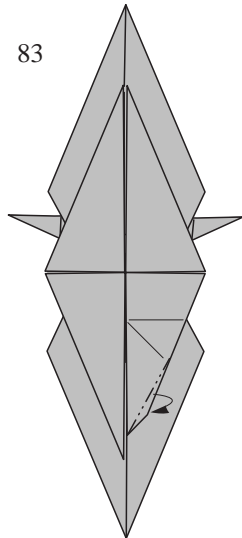
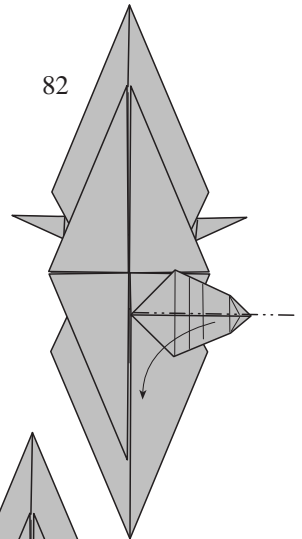
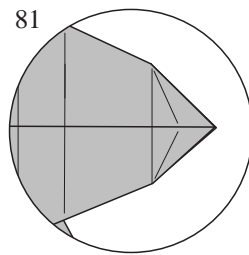
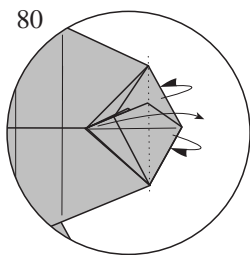
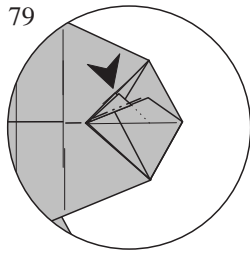
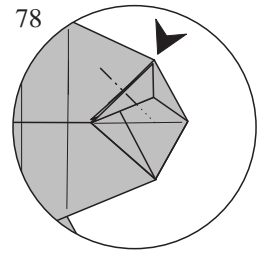
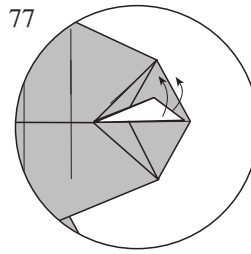
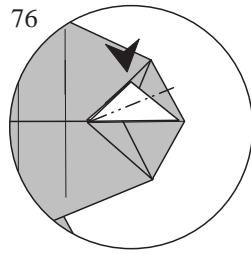
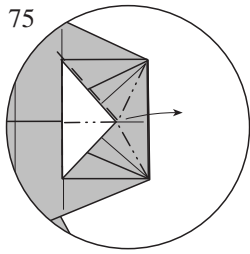

Repetir 61-84

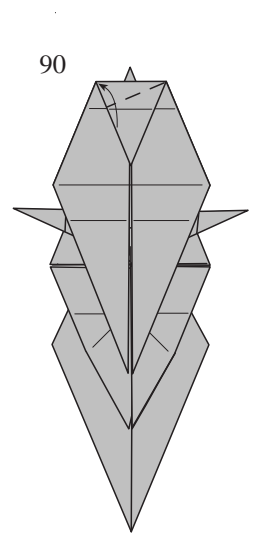
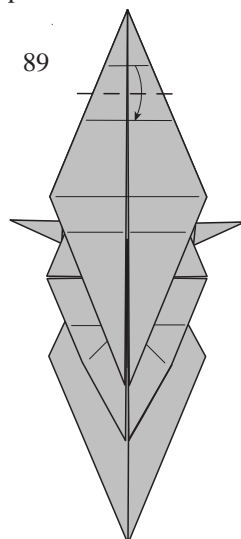
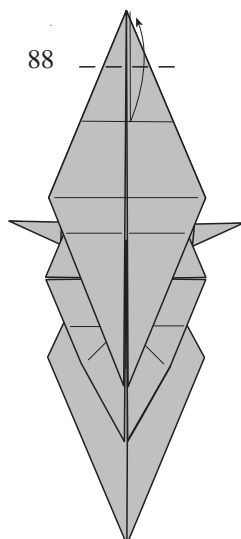
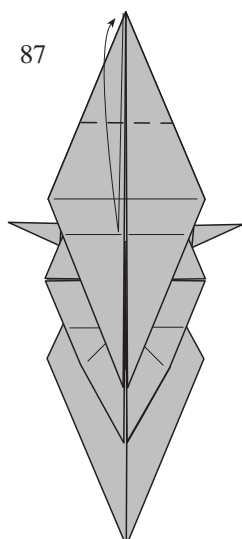

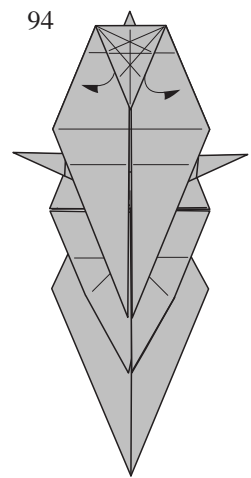
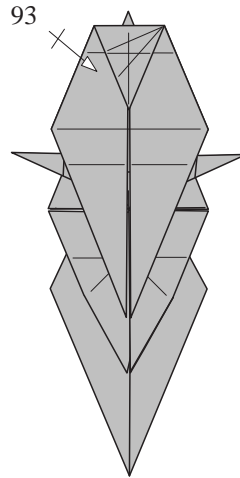
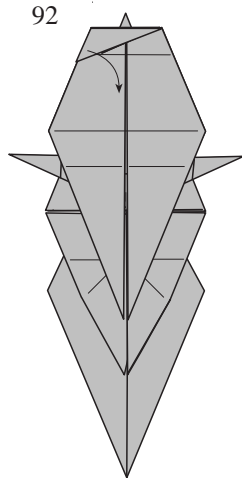
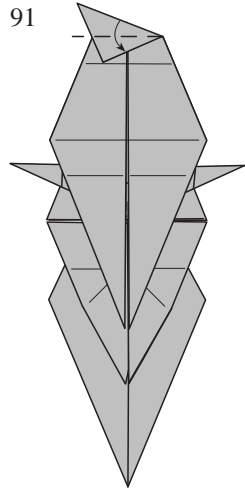

Repetir 90-92

Sacar

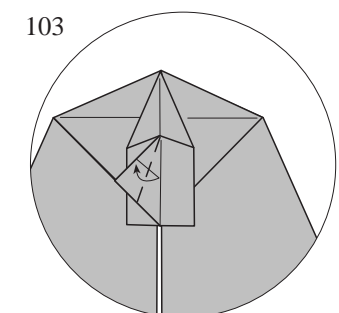
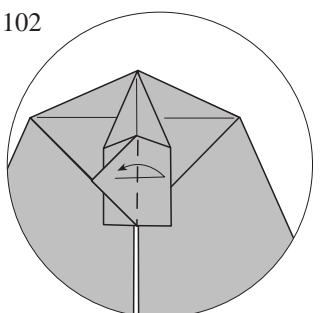
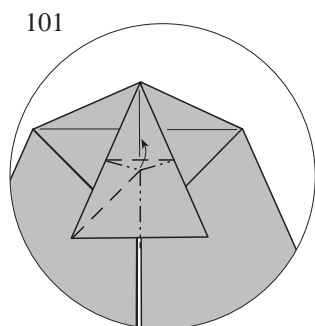
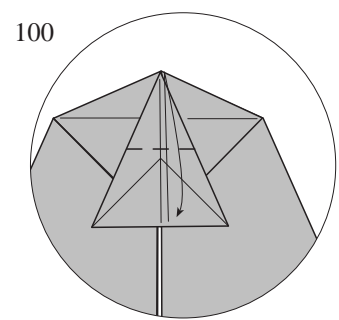
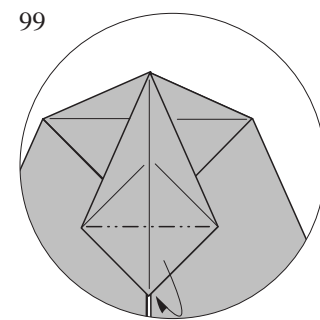
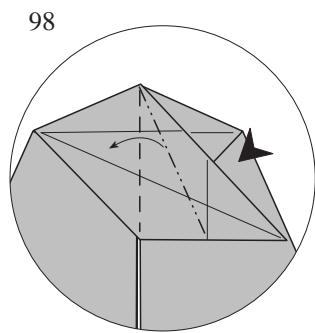
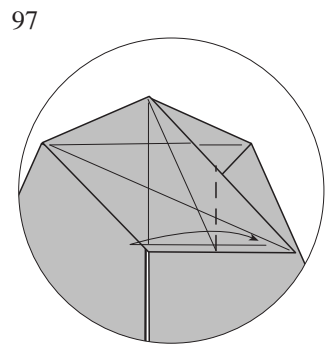
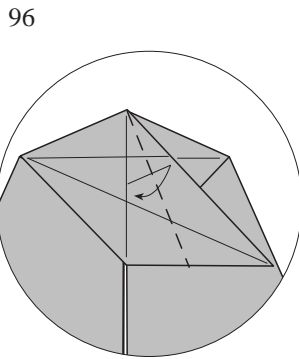
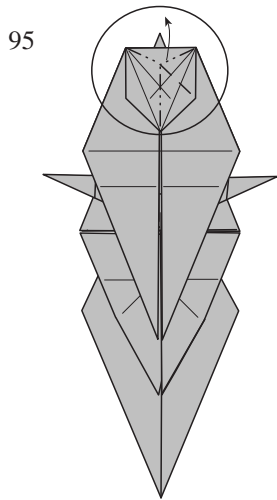

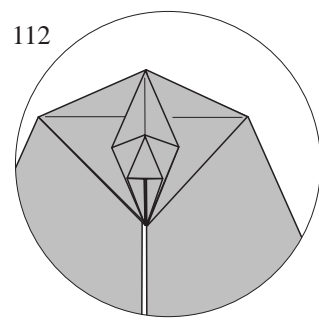
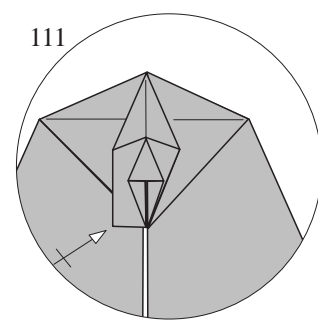
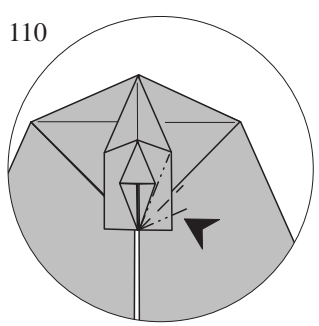
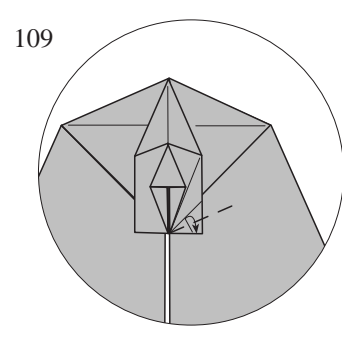
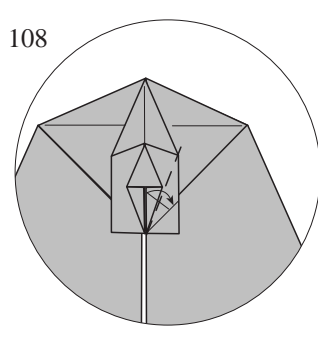
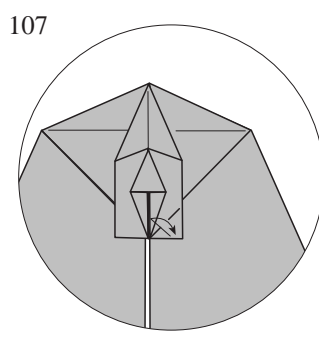
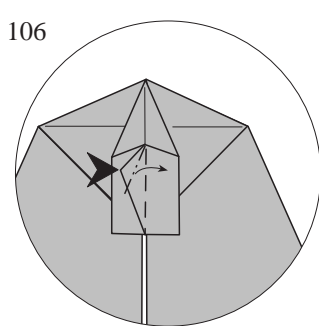
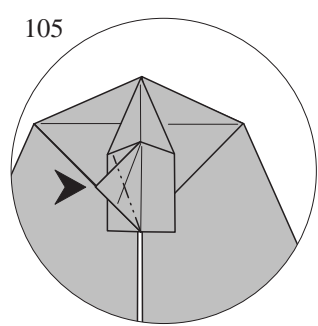
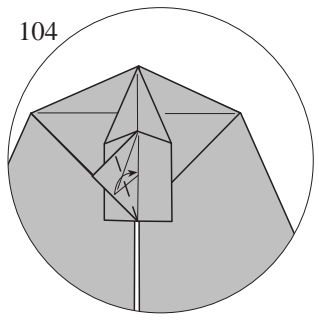

Repetir 107-110

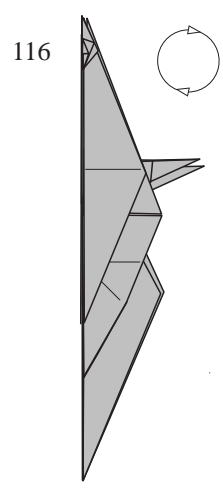
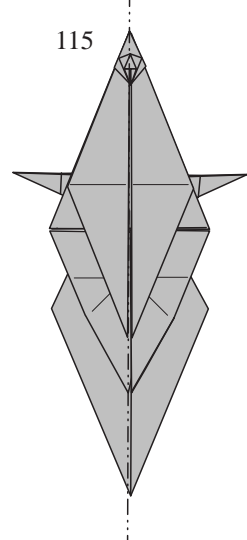
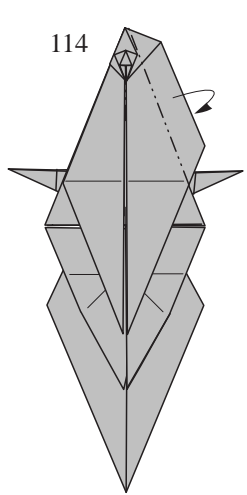
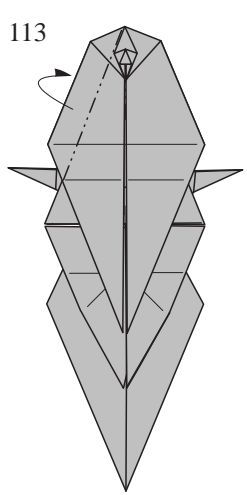

117

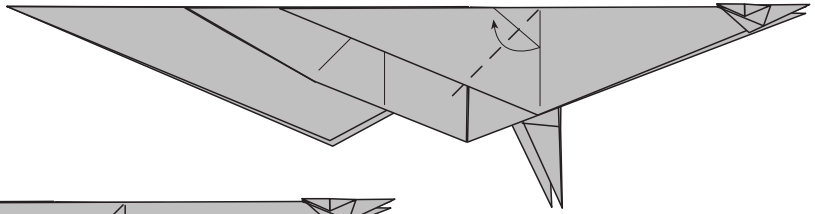

118

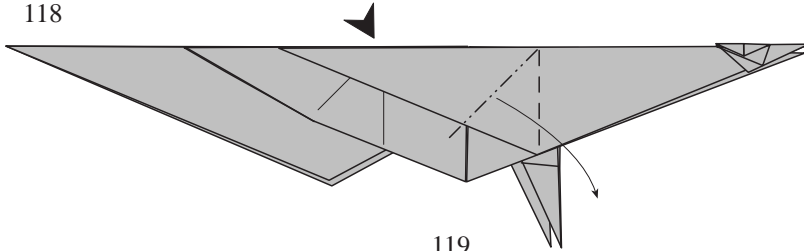

119

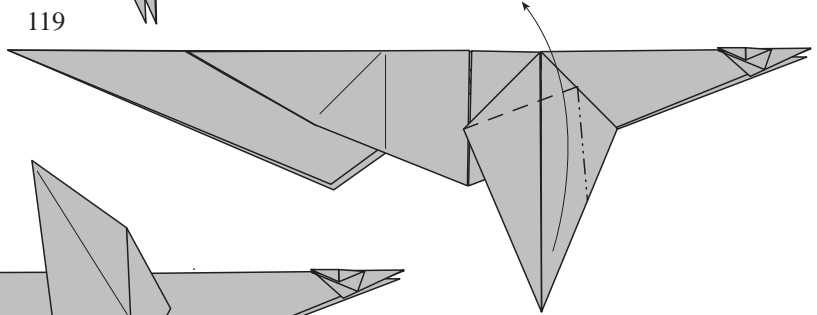

120

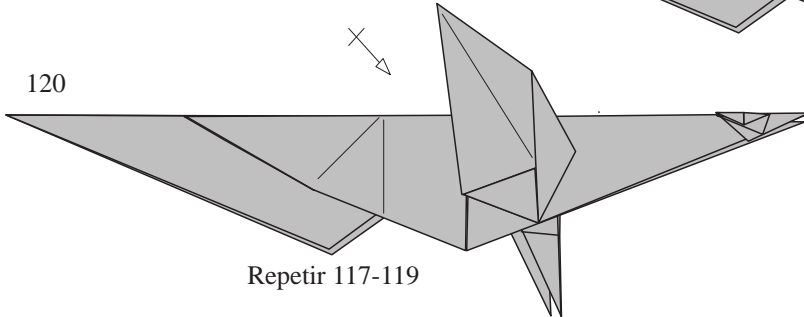

Repetir 117-119

121

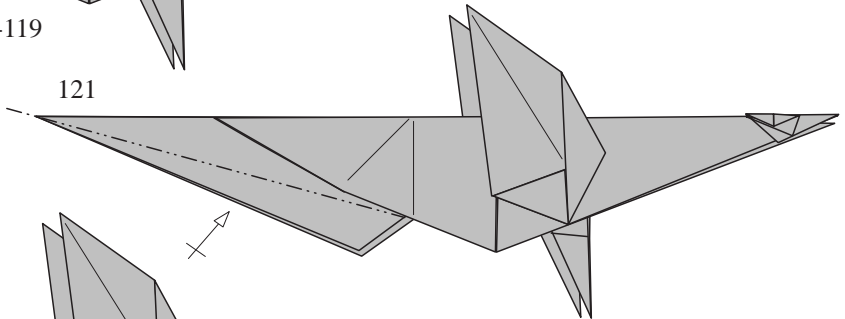

122

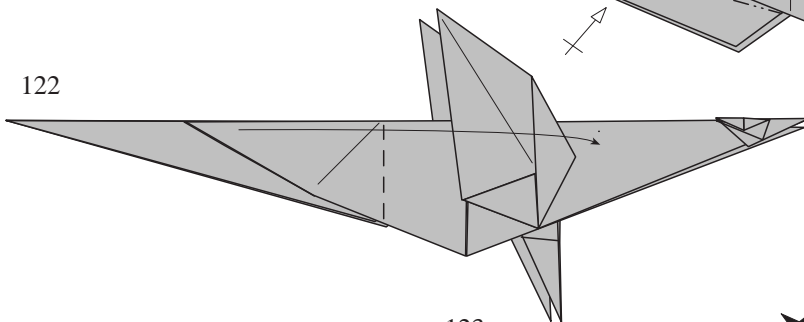

123

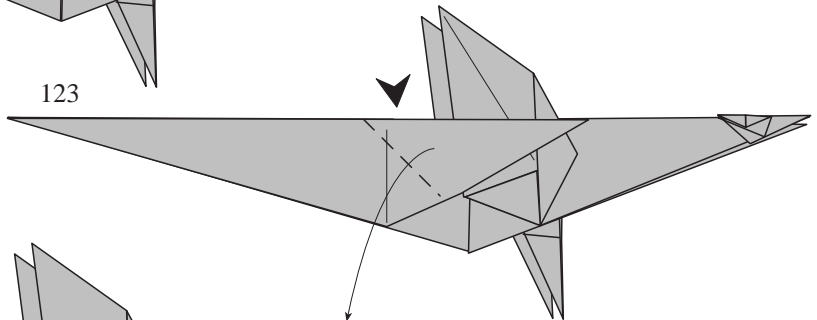

124

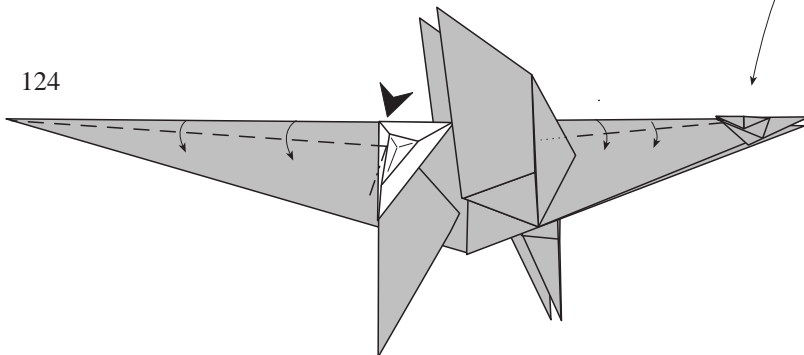

125

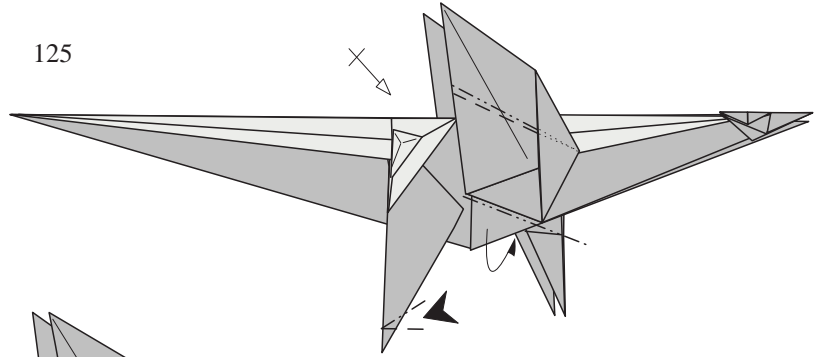

126

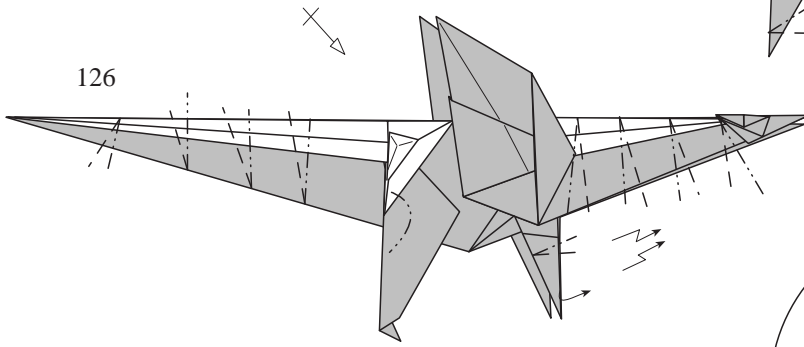

127

